

# R&S® TS-PWA3

## Test Versatile Platform R&S®

### PowerTSVP

## User Manual



1157.8143.12 – 15

This manual describes the following R&S®PowerTSVP models:

- R&S®1157.8043.02

© 2016 Rohde & Schwarz GmbH & Co. KG

Mühlhofstr. 15, 81671 München, Germany

Phone: +49 89 41 29 - 0

Fax: +49 89 41 29 12 164

Email: [info@rohde-schwarz.com](mailto:info@rohde-schwarz.com)

Internet: [www.rohde-schwarz.com](http://www.rohde-schwarz.com)

Subject to change – Data without tolerance limits is not binding.

R&S® is a registered trademark of Rohde & Schwarz GmbH & Co. KG.

Trade names are trademarks of the owners.

The following abbreviations are used throughout this manual: R&S®TS-PWA3 is abbreviated as R&S TS-PWA3.

# Basic Safety Instructions

## Always read through and comply with the following safety instructions!

All plants and locations of the Rohde & Schwarz group of companies make every effort to keep the safety standards of our products up to date and to offer our customers the highest possible degree of safety. Our products and the auxiliary equipment they require are designed, built and tested in accordance with the safety standards that apply in each case. Compliance with these standards is continuously monitored by our quality assurance system. The product described here has been designed, built and tested in accordance with the EC Certificate of Conformity and has left the manufacturer's plant in a condition fully complying with safety standards. To maintain this condition and to ensure safe operation, you must observe all instructions and warnings provided in this manual. If you have any questions regarding these safety instructions, the Rohde & Schwarz group of companies will be happy to answer them.







Furthermore, it is your responsibility to use the product in an appropriate manner. This product is designed for use solely in industrial and laboratory environments or, if expressly permitted, also in the field and must not be used in any way that may cause personal injury or property damage. You are responsible if the product is used for any purpose other than its designated purpose or in disregard of the manufacturer's instructions. The manufacturer shall assume no responsibility for such use of the product.

The product is used for its designated purpose if it is used in accordance with its product documentation and within its performance limits (see data sheet, documentation, the following safety instructions). Using the product requires technical skills and, in some cases, a basic knowledge of English. It is therefore essential that only skilled and specialized staff or thoroughly trained personnel with the required skills be allowed to use the product. If personal safety gear is required for using Rohde & Schwarz products, this will be indicated at the appropriate place in the product documentation. Keep the basic safety instructions and the product documentation in a safe place and pass them on to the subsequent users.











Observing the safety instructions will help prevent personal injury or damage of any kind caused by dangerous situations. Therefore, carefully read through and adhere to the following safety instructions before and when using the product. It is also absolutely essential to observe the additional safety instructions on personal safety, for example, that appear in relevant parts of the product documentation. In these safety instructions, the word "product" refers to all merchandise sold and distributed by the Rohde & Schwarz group of companies, including instruments, systems and all accessories. For product-specific information, see the data sheet and the product documentation.

## Safety labels on products

The following safety labels are used on products to warn against risks and dangers.

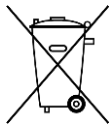
Symbol	Meaning	Symbol	Meaning
	Notice, general danger location Observe product documentation		ON/OFF Power
	Caution when handling heavy equipment		Standby indication
	Danger of electric shock		Direct current (DC)

## Basic Safety Instructions

Symbol	Meaning	Symbol	Meaning
	Caution ! Hot surface		Alternating current (AC)
	Protective conductor terminal To identify any terminal which is intended for connection to an external conductor for protection against electric shock in case of a fault, or the terminal of a protective earth		Direct/alternating current (DC/AC)
	Earth (Ground)		Class II Equipment to identify equipment meeting the safety requirements specified for Class II equipment (device protected by double or reinforced insulation)
	Frame or chassis Ground terminal		EU labeling for batteries and accumulators For additional information, see section "Waste disposal/Environmental protection", item 1.
	Be careful when handling electrostatic sensitive devices		EU labeling for separate collection of electrical and electronic devices For additional information, see section "Waste disposal/Environmental protection", item 2.
	Warning! Laser radiation For additional information, see section "Operation", item 7.		

### Signal words and their meaning

The following signal words are used in the product documentation in order to warn the reader about risks and dangers.



Indicates a hazardous situation which, if not avoided, will result in death or serious injury.



Indicates a hazardous situation which, if not avoided, could result in death or serious injury.



Indicates a hazardous situation which, if not avoided, could result in minor or moderate injury.



Indicates information considered important, but not hazard-related, e.g. messages relating to property damage.

In the product documentation, the word ATTENTION is used synonymously.

These signal words are in accordance with the standard definition for civil applications in the European Economic Area. Definitions that deviate from the standard definition may also exist in other economic areas or military applications. It is therefore essential to make sure that the signal words described here are always used only in connection with the related product documentation and the related product. The use of signal words in connection with unrelated products or documentation can result in misinterpretation and in personal injury or material damage.



## Basic Safety Instructions

### Operating states and operating positions

*The product may be operated only under the operating conditions and in the positions specified by the manufacturer, without the product's ventilation being obstructed. If the manufacturer's specifications are not observed, this can result in electric shock, fire and/or serious personal injury or death. Applicable local or national safety regulations and rules for the prevention of accidents must be observed in all work performed.*

1. Unless otherwise specified, the following requirements apply to Rohde & Schwarz products: predefined operating position is always with the housing floor facing down, IP protection 2X, use only indoors, max. operating altitude 2000 m above sea level, max. transport altitude 4500 m above sea level. A tolerance of  $\pm 10\%$  shall apply to the nominal voltage and  $\pm 5\%$  to the nominal frequency, overvoltage category 2, pollution degree 2.
2. Do not place the product on surfaces, vehicles, cabinets or tables that for reasons of weight or stability are unsuitable for this purpose. Always follow the manufacturer's installation instructions when installing the product and fastening it to objects or structures (e.g. walls and shelves). An installation that is not carried out as described in the product documentation could result in personal injury or even death.
3. Do not place the product on heat-generating devices such as radiators or fan heaters. The ambient temperature must not exceed the maximum temperature specified in the product documentation or in the data sheet. Product overheating can cause electric shock, fire and/or serious personal injury or even death.

### Electrical safety

*If the information on electrical safety is not observed either at all or to the extent necessary, electric shock, fire and/or serious personal injury or death may occur.*

1. Prior to switching on the product, always ensure that the nominal voltage setting on the product matches the nominal voltage of the mains-supply network. If a different voltage is to be set, the power fuse of the product may have to be changed accordingly.
2. In the case of products of safety class I with movable power cord and connector, operation is permitted only on sockets with a protective conductor contact and protective conductor.
3. Intentionally breaking the protective conductor either in the feed line or in the product itself is not permitted. Doing so can result in the danger of an electric shock from the product. If extension cords or connector strips are implemented, they must be checked on a regular basis to ensure that they are safe to use.
4. If there is no power switch for disconnecting the product from the mains, or if the power switch is not suitable for this purpose, use the plug of the connecting cable to disconnect the product from the mains. In such cases, always ensure that the power plug is easily reachable and accessible at all times. For example, if the power plug is the disconnecting device, the length of the connecting cable must not exceed 3 m. Functional or electronic switches are not suitable for providing disconnection from the AC supply network. If products without power switches are integrated into racks or systems, the disconnecting device must be provided at the system level.
5. Never use the product if the power cable is damaged. Check the power cables on a regular basis to ensure that they are in proper operating condition. By taking appropriate safety measures and carefully laying the power cable, ensure that the cable cannot be damaged and that no one can be hurt by, for example, tripping over the cable or suffering an electric shock.

## Basic Safety Instructions

6. The product may be operated only from TN/TT supply networks fuse-protected with max. 16 A (higher fuse only after consulting with the Rohde & Schwarz group of companies).
7. Do not insert the plug into sockets that are dusty or dirty. Insert the plug firmly and all the way into the socket provided for this purpose. Otherwise, sparks that result in fire and/or injuries may occur.
8. Do not overload any sockets, extension cords or connector strips; doing so can cause fire or electric shocks.
9. For measurements in circuits with voltages  $V_{rms} > 30$  V, suitable measures (e.g. appropriate measuring equipment, fuse protection, current limiting, electrical separation, insulation) should be taken to avoid any hazards.
10. Ensure that the connections with information technology equipment, e.g. PCs or other industrial computers, comply with the IEC 60950-1 / EN 60950-1 or IEC 61010-1 / EN 61010-1 standards that apply in each case.
11. Unless expressly permitted, never remove the cover or any part of the housing while the product is in operation. Doing so will expose circuits and components and can lead to injuries, fire or damage to the product.
12. If a product is to be permanently installed, the connection between the protective conductor terminal on site and the product's protective conductor must be made first before any other connection is made. The product may be installed and connected only by a licensed electrician.
13. For permanently installed equipment without built-in fuses, circuit breakers or similar protective devices, the supply circuit must be fuse-protected in such a way that anyone who has access to the product, as well as the product itself, is adequately protected from injury or damage.
14. Use suitable overvoltage protection to ensure that no overvoltage (such as that caused by a bolt of lightning) can reach the product. Otherwise, the person operating the product will be exposed to the danger of an electric shock.
15. Any object that is not designed to be placed in the openings of the housing must not be used for this purpose. Doing so can cause short circuits inside the product and/or electric shocks, fire or injuries.
16. Unless specified otherwise, products are not liquid-proof (see also section "Operating states and operating positions", item 1). Therefore, the equipment must be protected against penetration by liquids. If the necessary precautions are not taken, the user may suffer electric shock or the product itself may be damaged, which can also lead to personal injury.
17. Never use the product under conditions in which condensation has formed or can form in or on the product, e.g. if the product has been moved from a cold to a warm environment. Penetration by water increases the risk of electric shock.
18. Prior to cleaning the product, disconnect it completely from the power supply (e.g. AC supply network or battery). Use a soft, non-linting cloth to clean the product. Never use chemical cleaning agents such as alcohol, acetone or diluents for cellulose lacquers.

## Operation

1. Operating the products requires special training and intense concentration. Make sure that persons who use the products are physically, mentally and emotionally fit enough to do so; otherwise, injuries or material damage may occur. It is the responsibility of the employer/operator to select suitable personnel for operating the products.

## Basic Safety Instructions

2. Before you move or transport the product, read and observe the section titled "Transport".
3. As with all industrially manufactured goods, the use of substances that induce an allergic reaction (allergens) such as nickel cannot be generally excluded. If you develop an allergic reaction (such as a skin rash, frequent sneezing, red eyes or respiratory difficulties) when using a Rohde & Schwarz product, consult a physician immediately to determine the cause and to prevent health problems or stress.
4. Before you start processing the product mechanically and/or thermally, or before you take it apart, be sure to read and pay special attention to the section titled "Waste disposal/Environmental protection", item 1.
5. Depending on the function, certain products such as RF radio equipment can produce an elevated level of electromagnetic radiation. Considering that unborn babies require increased protection, pregnant women must be protected by appropriate measures. Persons with pacemakers may also be exposed to risks from electromagnetic radiation. The employer/operator must evaluate workplaces where there is a special risk of exposure to radiation and, if necessary, take measures to avert the potential danger.
6. Should a fire occur, the product may release hazardous substances (gases, fluids, etc.) that can cause health problems. Therefore, suitable measures must be taken, e.g. protective masks and protective clothing must be worn.
7. Laser products are given warning labels that are standardized according to their laser class. Lasers can cause biological harm due to the properties of their radiation and due to their extremely concentrated electromagnetic power. If a laser product (e.g. a CD/DVD drive) is integrated into a Rohde & Schwarz product, absolutely no other settings or functions may be used as described in the product documentation. The objective is to prevent personal injury (e.g. due to laser beams).
8. EMC classes (in line with EN 55011/CISPR 11, and analogously with EN 55022/CISPR 22, EN 55032/CISPR 32)
  - Class A equipment:  
Equipment suitable for use in all environments except residential environments and environments that are directly connected to a low-voltage supply network that supplies residential buildings  
Note: Class A equipment is intended for use in an industrial environment. This equipment may cause radio disturbances in residential environments, due to possible conducted as well as radiated disturbances. In this case, the operator may be required to take appropriate measures to eliminate these disturbances.
  - Class B equipment:  
Equipment suitable for use in residential environments and environments that are directly connected to a low-voltage supply network that supplies residential buildings

### Repair and service

1. The product may be opened only by authorized, specially trained personnel. Before any work is performed on the product or before the product is opened, it must be disconnected from the AC supply network. Otherwise, personnel will be exposed to the risk of an electric shock.

## Basic Safety Instructions

- Adjustments, replacement of parts, maintenance and repair may be performed only by electrical experts authorized by Rohde & Schwarz. Only original parts may be used for replacing parts relevant to safety (e.g. power switches, power transformers, fuses). A safety test must always be performed after parts relevant to safety have been replaced (visual inspection, protective conductor test, insulation resistance measurement, leakage current measurement, functional test). This helps ensure the continued safety of the product.

### Batteries and rechargeable batteries/cells

*If the information regarding batteries and rechargeable batteries/cells is not observed either at all or to the extent necessary, product users may be exposed to the risk of explosions, fire and/or serious personal injury, and, in some cases, death. Batteries and rechargeable batteries with alkaline electrolytes (e.g. lithium cells) must be handled in accordance with the EN 62133 standard.*

- Cells must not be taken apart or crushed.
- Cells or batteries must not be exposed to heat or fire. Storage in direct sunlight must be avoided. Keep cells and batteries clean and dry. Clean soiled connectors using a dry, clean cloth.
- Cells or batteries must not be short-circuited. Cells or batteries must not be stored in a box or in a drawer where they can short-circuit each other, or where they can be short-circuited by other conductive materials. Cells and batteries must not be removed from their original packaging until they are ready to be used.
- Cells and batteries must not be exposed to any mechanical shocks that are stronger than permitted.
- If a cell develops a leak, the fluid must not be allowed to come into contact with the skin or eyes. If contact occurs, wash the affected area with plenty of water and seek medical aid.
- Improperly replacing or charging cells or batteries that contain alkaline electrolytes (e.g. lithium cells) can cause explosions. Replace cells or batteries only with the matching Rohde & Schwarz type (see parts list) in order to ensure the safety of the product.
- Cells and batteries must be recycled and kept separate from residual waste. Rechargeable batteries and normal batteries that contain lead, mercury or cadmium are hazardous waste. Observe the national regulations regarding waste disposal and recycling.

### Transport

- The product may be very heavy. Therefore, the product must be handled with care. In some cases, the user may require a suitable means of lifting or moving the product (e.g. with a lift-truck) to avoid back or other physical injuries.
- Handles on the products are designed exclusively to enable personnel to transport the product. It is therefore not permissible to use handles to fasten the product to or on transport equipment such as cranes, fork lifts, wagons, etc. The user is responsible for securely fastening the products to or on the means of transport or lifting. Observe the safety regulations of the manufacturer of the means of transport or lifting. Noncompliance can result in personal injury or material damage.
- If you use the product in a vehicle, it is the sole responsibility of the driver to drive the vehicle safely and properly. The manufacturer assumes no responsibility for accidents or collisions. Never use the product in a moving vehicle if doing so could distract the driver of the vehicle. Adequately secure the product in the vehicle to prevent injuries or other damage in the event of an accident.

## Instrucciones de seguridad elementales

### Waste disposal/Environmental protection

1. Specially marked equipment has a battery or accumulator that must not be disposed of with unsorted municipal waste, but must be collected separately. It may only be disposed of at a suitable collection point or via a Rohde & Schwarz customer service center.
2. Waste electrical and electronic equipment must not be disposed of with unsorted municipal waste, but must be collected separately.  
Rohde & Schwarz GmbH & Co. KG has developed a disposal concept and takes full responsibility for take-back obligations and disposal obligations for manufacturers within the EU. Contact your Rohde & Schwarz customer service center for environmentally responsible disposal of the product.
3. If products or their components are mechanically and/or thermally processed in a manner that goes beyond their intended use, hazardous substances (heavy-metal dust such as lead, beryllium, nickel) may be released. For this reason, the product may only be disassembled by specially trained personnel. Improper disassembly may be hazardous to your health. National waste disposal regulations must be observed.
4. If handling the product releases hazardous substances or fuels that must be disposed of in a special way, e.g. coolants or engine oils that must be replenished regularly, the safety instructions of the manufacturer of the hazardous substances or fuels and the applicable regional waste disposal regulations must be observed. Also observe the relevant safety instructions in the product documentation. The improper disposal of hazardous substances or fuels can cause health problems and lead to environmental damage.

For additional information about environmental protection, visit the Rohde & Schwarz website.

## Instrucciones de seguridad elementales

### **¡Es imprescindible leer y cumplir las siguientes instrucciones e informaciones de seguridad!**

El principio del grupo de empresas Rohde & Schwarz consiste en tener nuestros productos siempre al día con los estándares de seguridad y de ofrecer a nuestros clientes el máximo grado de seguridad. Nuestros productos y todos los equipos adicionales son siempre fabricados y examinados según las normas de seguridad vigentes. Nuestro sistema de garantía de calidad controla constantemente que sean cumplidas estas normas. El presente producto ha sido fabricado y examinado según el certificado de conformidad de la UE y ha salido de nuestra planta en estado impecable según los estándares técnicos de seguridad. Para poder preservar este estado y garantizar un funcionamiento libre de peligros, el usuario deberá atenerse a todas las indicaciones, informaciones de seguridad y notas de alerta. El grupo de empresas Rohde & Schwarz está siempre a su disposición en caso de que tengan preguntas referentes a estas informaciones de seguridad.

Además queda en la responsabilidad del usuario utilizar el producto en la forma debida. Este producto está destinado exclusivamente al uso en la industria y el laboratorio o, si ha sido expresamente autorizado, para aplicaciones de campo y de ninguna manera deberá ser utilizado de modo que alguna persona/cosa pueda sufrir daño. El uso del producto fuera de sus fines definidos o sin tener en cuenta las instrucciones del fabricante queda en la responsabilidad del usuario. El fabricante no se hace en ninguna forma responsable de consecuencias a causa del mal uso del producto.















## Instrucciones de seguridad elementales

Se parte del uso correcto del producto para los fines definidos si el producto es utilizado conforme a las indicaciones de la correspondiente documentación del producto y dentro del margen de rendimiento definido (ver hoja de datos, documentación, informaciones de seguridad que siguen). El uso del producto hace necesarios conocimientos técnicos y ciertos conocimientos del idioma inglés. Por eso se debe tener en cuenta que el producto solo pueda ser operado por personal especializado o personas instruidas en profundidad con las capacidades correspondientes. Si fuera necesaria indumentaria de seguridad para el uso de productos de Rohde & Schwarz, encontraría la información debida en la documentación del producto en el capítulo correspondiente. Guarde bien las informaciones de seguridad elementales, así como la documentación del producto, y entréguelas a usuarios posteriores.



Tener en cuenta las informaciones de seguridad sirve para evitar en lo posible lesiones o daños por peligros de toda clase. Por eso es imprescindible leer detalladamente y comprender por completo las siguientes informaciones de seguridad antes de usar el producto, y respetarlas durante el uso del producto. Deberán tenerse en cuenta todas las demás informaciones de seguridad, como p. ej. las referentes a la protección de personas, que encontrarán en el capítulo correspondiente de la documentación del producto y que también son de obligado cumplimiento. En las presentes informaciones de seguridad se recogen todos los objetos que distribuye el grupo de empresas Rohde & Schwarz bajo la denominación de "producto", entre ellos también aparatos, instalaciones así como toda clase de accesorios. Los datos específicos del producto figuran en la hoja de datos y en la documentación del producto.

### Señalización de seguridad de los productos

Las siguientes señales de seguridad se utilizan en los productos para advertir sobre riesgos y peligros.

Símbolo	Significado	Símbolo	Significado
	Aviso: punto de peligro general Observar la documentación del producto		Tensión de alimentación de PUESTA EN MARCHA / PARADA
	Atención en el manejo de dispositivos de peso elevado		Indicación de estado de espera (standby)
	Peligro de choque eléctrico		Corriente continua (DC)
	Advertencia: superficie caliente		Corriente alterna (AC)
	Conexión a conductor de protección		Corriente continua / Corriente alterna (DC/AC)
	Conexión a tierra		El aparato está protegido en su totalidad por un aislamiento doble (reforzado)
	Conexión a masa		Distintivo de la UE para baterías y acumuladores Más información en la sección "Eliminación/protección del medio ambiente", punto 1.

## Instrucciones de seguridad elementales

Símbolo	Significado	Símbolo	Significado
	Aviso: Cuidado en el manejo de dispositivos sensibles a la electrostática (ESD)		Distintivo de la UE para la eliminación por separado de dispositivos eléctricos y electrónicos  Más información en la sección "Eliminación/protección del medio ambiente", punto 2.
	Advertencia: rayo láser  Más información en la sección "Funcionamiento", punto 7.		

### Palabras de señal y su significado

En la documentación del producto se utilizan las siguientes palabras de señal con el fin de advertir contra riesgos y peligros.



Indica una situación de peligro que, si no se evita, causa lesiones graves o incluso la muerte.



Indica una situación de peligro que, si no se evita, puede causar lesiones graves o incluso la muerte.



Indica una situación de peligro que, si no se evita, puede causar lesiones leves o moderadas.



Indica información que se considera importante, pero no en relación con situaciones de peligro; p. ej., avisos sobre posibles daños materiales.

En la documentación del producto se emplea de forma sinónima el término CUIDADO.

Las palabras de señal corresponden a la definición habitual para aplicaciones civiles en el área económica europea. Pueden existir definiciones diferentes a esta definición en otras áreas económicas o en aplicaciones militares. Por eso se deberá tener en cuenta que las palabras de señal aquí descritas sean utilizadas siempre solamente en combinación con la correspondiente documentación del producto y solamente en combinación con el producto correspondiente. La utilización de las palabras de señal en combinación con productos o documentaciones que no les correspondan puede llevar a interpretaciones equivocadas y tener por consecuencia daños en personas u objetos.

### Estados operativos y posiciones de funcionamiento

*El producto solamente debe ser utilizado según lo indicado por el fabricante respecto a los estados operativos y posiciones de funcionamiento sin que se obstruya la ventilación. Si no se siguen las indicaciones del fabricante, pueden producirse choques eléctricos, incendios y/o lesiones graves con posible consecuencia de muerte. En todos los trabajos deberán ser tenidas en cuenta las normas nacionales y locales de seguridad del trabajo y de prevención de accidentes.*



## Instrucciones de seguridad elementales

1. Si no se convino de otra manera, es para los productos Rohde & Schwarz válido lo que sigue: como posición de funcionamiento se define por principio la posición con el suelo de la caja para abajo, modo de protección IP 2X, uso solamente en estancias interiores, utilización hasta 2000 m sobre el nivel del mar, transporte hasta 4500 m sobre el nivel del mar. Se aplicará una tolerancia de  $\pm 10\%$  sobre el voltaje nominal y de  $\pm 5\%$  sobre la frecuencia nominal. Categoría de sobrecarga eléctrica 2, índice de suciedad 2.
2. No sitúe el producto encima de superficies, vehículos, estantes o mesas, que por sus características de peso o de estabilidad no sean aptos para él. Siga siempre las instrucciones de instalación del fabricante cuando instale y asegure el producto en objetos o estructuras (p. ej. paredes y estantes). Si se realiza la instalación de modo distinto al indicado en la documentación del producto, se pueden causar lesiones o, en determinadas circunstancias, incluso la muerte.
3. No ponga el producto sobre aparatos que generen calor (p. ej. radiadores o calefactores). La temperatura ambiente no debe superar la temperatura máxima especificada en la documentación del producto o en la hoja de datos. En caso de sobrecalentamiento del producto, pueden producirse choques eléctricos, incendios y/o lesiones graves con posible consecuencia de muerte.

### Seguridad eléctrica

*Si no se siguen (o se siguen de modo insuficiente) las indicaciones del fabricante en cuanto a seguridad eléctrica, pueden producirse choques eléctricos, incendios y/o lesiones graves con posible consecuencia de muerte.*

1. Antes de la puesta en marcha del producto se deberá comprobar siempre que la tensión preseleccionada en el producto coincida con la de la red de alimentación eléctrica. Si es necesario modificar el ajuste de tensión, también se deberán cambiar en caso dado los fusibles correspondientes del producto.
2. Los productos de la clase de protección I con alimentación móvil y enchufe individual solamente podrán enchufarse a tomas de corriente con contacto de seguridad y con conductor de protección conectado.
3. Queda prohibida la interrupción intencionada del conductor de protección, tanto en la toma de corriente como en el mismo producto. La interrupción puede tener como consecuencia el riesgo de que el producto sea fuente de choques eléctricos. Si se utilizan cables alargadores o regletas de enchufe, deberá garantizarse la realización de un examen regular de los mismos en cuanto a su estado técnico de seguridad.
4. Si el producto no está equipado con un interruptor para desconectarlo de la red, o bien si el interruptor existente no resulta apropiado para la desconexión de la red, el enchufe del cable de conexión se deberá considerar como un dispositivo de desconexión. El dispositivo de desconexión se debe poder alcanzar fácilmente y debe estar siempre bien accesible. Si, p. ej., el enchufe de conexión a la red es el dispositivo de desconexión, la longitud del cable de conexión no debe superar 3 m). Los interruptores selectores o electrónicos no son aptos para el corte de la red eléctrica. Si se integran productos sin interruptor en bastidores o instalaciones, se deberá colocar el interruptor en el nivel de la instalación.
5. No utilice nunca el producto si está dañado el cable de conexión a red. Compruebe regularmente el correcto estado de los cables de conexión a red. Asegúrese, mediante las medidas de protección y de instalación adecuadas, de que el cable de conexión a red no pueda ser dañado o de que nadie pueda ser dañado por él, p. ej. al tropezar o por un choque eléctrico.

## Instrucciones de seguridad elementales

6. Solamente está permitido el funcionamiento en redes de alimentación TN/TT aseguradas con fusibles de 16 A como máximo (utilización de fusibles de mayor amperaje solo previa consulta con el grupo de empresas Rohde & Schwarz).
7. Nunca conecte el enchufe en tomas de corriente sucias o llenas de polvo. Introduzca el enchufe por completo y fuertemente en la toma de corriente. La no observación de estas medidas puede provocar chispas, fuego y/o lesiones.
8. No sobrecargue las tomas de corriente, los cables alargadores o las regletas de enchufe ya que esto podría causar fuego o choques eléctricos.
9. En las mediciones en circuitos de corriente con una tensión  $U_{\text{eff}} > 30 \text{ V}$  se deberán tomar las medidas apropiadas para impedir cualquier peligro (p. ej. medios de medición adecuados, seguros, limitación de tensión, corte protector, aislamiento etc.).
10. Para la conexión con dispositivos informáticos como un PC o un ordenador industrial, debe comprobarse que éstos cumplan los estándares IEC60950-1/EN60950-1 o IEC61010-1/EN 61010-1 válidos en cada caso.
11. A menos que esté permitido expresamente, no retire nunca la tapa ni componentes de la carcasa mientras el producto esté en servicio. Esto pone a descubierto los cables y componentes eléctricos y puede causar lesiones, fuego o daños en el producto.
12. Si un producto se instala en un lugar fijo, se deberá primero conectar el conductor de protección fijo con el conductor de protección del producto antes de hacer cualquier otra conexión. La instalación y la conexión deberán ser efectuadas por un electricista especializado.
13. En el caso de dispositivos fijos que no estén provistos de fusibles, interruptor automático ni otros mecanismos de seguridad similares, el circuito de alimentación debe estar protegido de modo que todas las personas que puedan acceder al producto, así como el producto mismo, estén a salvo de posibles daños.
14. Todo producto debe estar protegido contra sobretensión (debida p. ej. a una caída del rayo) mediante los correspondientes sistemas de protección. Si no, el personal que lo utilice quedará expuesto al peligro de choque eléctrico.
15. No debe introducirse en los orificios de la caja del aparato ningún objeto que no esté destinado a ello. Esto puede producir cortocircuitos en el producto y/o puede causar choques eléctricos, fuego o lesiones.
16. Salvo indicación contraria, los productos no están impermeabilizados (ver también el capítulo "Estados operativos y posiciones de funcionamiento", punto 1). Por eso es necesario tomar las medidas necesarias para evitar la entrada de líquidos. En caso contrario, existe peligro de choque eléctrico para el usuario o de daños en el producto, que también pueden redundar en peligro para las personas.
17. No utilice el producto en condiciones en las que pueda producirse o ya se hayan producido condensaciones sobre el producto o en el interior de éste, como p. ej. al desplazarlo de un lugar frío a otro caliente. La entrada de agua aumenta el riesgo de choque eléctrico.
18. Antes de la limpieza, desconecte por completo el producto de la alimentación de tensión (p. ej. red de alimentación o batería). Realice la limpieza de los aparatos con un paño suave, que no se deshilache. No utilice bajo ningún concepto productos de limpieza químicos como alcohol, acetona o diluyentes para lacas nitrocelulósicas.

## Instrucciones de seguridad elementales

### Funcionamiento

1. El uso del producto requiere instrucciones especiales y una alta concentración durante el manejo. Debe asegurarse que las personas que manejen el producto estén a la altura de los requerimientos necesarios en cuanto a aptitudes físicas, psíquicas y emocionales, ya que de otra manera no se pueden excluir lesiones o daños de objetos. El empresario u operador es responsable de seleccionar el personal usuario apto para el manejo del producto.
2. Antes de desplazar o transportar el producto, lea y tenga en cuenta el capítulo "Transporte".
3. Como con todo producto de fabricación industrial no puede quedar excluida en general la posibilidad de que se produzcan alergias provocadas por algunos materiales empleados —los llamados alérgenos (p. ej. el níquel)—. Si durante el manejo de productos Rohde & Schwarz se producen reacciones alérgicas, como p. ej. irritaciones cutáneas, estornudos continuos, enrojecimiento de la conjuntiva o dificultades respiratorias, debe avisarse inmediatamente a un médico para investigar las causas y evitar cualquier molestia o daño a la salud.
4. Antes de la manipulación mecánica y/o térmica o el desmontaje del producto, debe tenerse en cuenta imprescindiblemente el capítulo "Eliminación/protección del medio ambiente", punto 1.
5. Ciertos productos, como p. ej. las instalaciones de radiocomunicación RF, pueden a causa de su función natural, emitir una radiación electromagnética aumentada. Deben tomarse todas las medidas necesarias para la protección de las mujeres embarazadas. También las personas con marcapasos pueden correr peligro a causa de la radiación electromagnética. El empresario/operador tiene la obligación de evaluar y señalizar las áreas de trabajo en las que exista un riesgo elevado de exposición a radiaciones.
6. Tenga en cuenta que en caso de incendio pueden desprenderse del producto sustancias tóxicas (gases, líquidos etc.) que pueden generar daños a la salud. Por eso, en caso de incendio deben usarse medidas adecuadas, como p. ej. máscaras antigás e indumentaria de protección.
7. Los productos con láser están provistos de indicaciones de advertencia normalizadas en función de la clase de láser del que se trate. Los rayos láser pueden provocar daños de tipo biológico a causa de las propiedades de su radiación y debido a su concentración extrema de potencia electromagnética. En caso de que un producto Rohde & Schwarz contenga un producto láser (p. ej. un lector de CD/DVD), no debe usarse ninguna otra configuración o función aparte de las descritas en la documentación del producto, a fin de evitar lesiones (p. ej. debidas a irradiación láser).
8. Clases de compatibilidad electromagnética (conforme a EN 55011 / CISPR 11; y en analogía con EN 55022 / CISPR 22, EN 55032 / CISPR 32)
  - Aparato de clase A:  
Aparato adecuado para su uso en todos los entornos excepto en los residenciales y en aquellos conectados directamente a una red de distribución de baja tensión que suministra corriente a edificios residenciales.  
Nota: Los aparatos de clase A están destinados al uso en entornos industriales. Estos aparatos pueden causar perturbaciones radioeléctricas en entornos residenciales debido a posibles perturbaciones guiadas o radiadas. En este caso, se le podrá solicitar al operador que tome las medidas adecuadas para eliminar estas perturbaciones.
  - Aparato de clase B:  
Aparato adecuado para su uso en entornos residenciales, así como en aquellos conectados directamente a una red de distribución de baja tensión que suministra corriente a edificios residenciales.

## Instrucciones de seguridad elementales

### Reparación y mantenimiento

1. El producto solamente debe ser abierto por personal especializado con autorización para ello. Antes de manipular el producto o abrirlo, es obligatorio desconectarlo de la tensión de alimentación, para evitar toda posibilidad de choque eléctrico.
2. El ajuste, el cambio de partes, el mantenimiento y la reparación deberán ser efectuadas solamente por electricistas autorizados por Rohde & Schwarz. Si se reponen partes con importancia para los aspectos de seguridad (p. ej. el enchufe, los transformadores o los fusibles), solamente podrán ser sustituidos por partes originales. Después de cada cambio de partes relevantes para la seguridad deberá realizarse un control de seguridad (control a primera vista, control del conductor de protección, medición de resistencia de aislamiento, medición de la corriente de fuga, control de funcionamiento). Con esto queda garantizada la seguridad del producto.

### Baterías y acumuladores o celdas

*Si no se siguen (o se siguen de modo insuficiente) las indicaciones en cuanto a las baterías y acumuladores o celdas, pueden producirse explosiones, incendios y/o lesiones graves con posible consecuencia de muerte. El manejo de baterías y acumuladores con electrolitos alcalinos (p. ej. celdas de litio) debe seguir el estándar EN 62133.*

1. No deben desmontarse, abrirse ni triturarse las celdas.
2. Las celdas o baterías no deben someterse a calor ni fuego. Debe evitarse el almacenamiento a la luz directa del sol. Las celdas y baterías deben mantenerse limpias y secas. Limpiar las conexiones sucias con un paño seco y limpio.
3. Las celdas o baterías no deben cortocircuitarse. Es peligroso almacenar las celdas o baterías en estuches o cajones en cuyo interior puedan cortocircuitarse por contacto recíproco o por contacto con otros materiales conductores. No deben extraerse las celdas o baterías de sus embalajes originales hasta el momento en que vayan a utilizarse.
4. Las celdas o baterías no deben someterse a impactos mecánicos fuertes indebidos.
5. En caso de falta de estanqueidad de una celda, el líquido vertido no debe entrar en contacto con la piel ni los ojos. Si se produce contacto, lavar con agua abundante la zona afectada y avisar a un médico.
6. En caso de cambio o recarga inadecuados, las celdas o baterías que contienen electrolitos alcalinos (p. ej. las celdas de litio) pueden explotar. Para garantizar la seguridad del producto, las celdas o baterías solo deben ser sustituidas por el tipo Rohde & Schwarz correspondiente (ver lista de recambios).
7. Las baterías y celdas deben reciclarse y no deben tirarse a la basura doméstica. Las baterías o acumuladores que contienen plomo, mercurio o cadmio deben tratarse como residuos especiales. Respete en esta relación las normas nacionales de eliminación y reciclaje.

### Transporte

1. El producto puede tener un peso elevado. Por eso es necesario desplazarlo o transportarlo con precaución y, si es necesario, usando un sistema de elevación adecuado (p. ej. una carretilla elevadora), a fin de evitar lesiones en la espalda u otros daños personales.

## Instrucciones de seguridad elementales

2. Las asas instaladas en los productos sirven solamente de ayuda para el transporte del producto por personas. Por eso no está permitido utilizar las asas para la sujeción en o sobre medios de transporte como p. ej. grúas, carretillas elevadoras de horquilla, carros etc. Es responsabilidad suya fijar los productos de manera segura a los medios de transporte o elevación. Para evitar daños personales o daños en el producto, siga las instrucciones de seguridad del fabricante del medio de transporte o elevación utilizado.
3. Si se utiliza el producto dentro de un vehículo, recae de manera exclusiva en el conductor la responsabilidad de conducir el vehículo de manera segura y adecuada. El fabricante no asumirá ninguna responsabilidad por accidentes o colisiones. No utilice nunca el producto dentro de un vehículo en movimiento si esto pudiera distraer al conductor. Asegure el producto dentro del vehículo debidamente para evitar, en caso de un accidente, lesiones u otra clase de daños.

### Eliminación/protección del medio ambiente

1. Los dispositivos marcados contienen una batería o un acumulador que no se debe desechar con los residuos domésticos sin clasificar, sino que debe ser recogido por separado. La eliminación se debe efectuar exclusivamente a través de un punto de recogida apropiado o del servicio de atención al cliente de Rohde & Schwarz.
2. Los dispositivos eléctricos usados no se deben desechar con los residuos domésticos sin clasificar, sino que deben ser recogidos por separado.  
Rohde & Schwarz GmbH & Co.KG ha elaborado un concepto de eliminación de residuos y asume plenamente los deberes de recogida y eliminación para los fabricantes dentro de la UE. Para desechar el producto de manera respetuosa con el medio ambiente, dirijase a su servicio de atención al cliente de Rohde & Schwarz.
3. Si se trabaja de manera mecánica y/o térmica cualquier producto o componente más allá del funcionamiento previsto, pueden liberarse sustancias peligrosas (polvos con contenido de metales pesados como p. ej. plomo, berilio o níquel). Por eso el producto solo debe ser desmontado por personal especializado con formación adecuada. Un desmontaje inadecuado puede ocasionar daños para la salud. Se deben tener en cuenta las directivas nacionales referentes a la eliminación de residuos.
4. En caso de que durante el trato del producto se formen sustancias peligrosas o combustibles que deban tratarse como residuos especiales (p. ej. refrigerantes o aceites de motor con intervalos de cambio definidos), deben tenerse en cuenta las indicaciones de seguridad del fabricante de dichas sustancias y las normas regionales de eliminación de residuos. Tenga en cuenta también en caso necesario las indicaciones de seguridad especiales contenidas en la documentación del producto. La eliminación incorrecta de sustancias peligrosas o combustibles puede causar daños a la salud o daños al medio ambiente.

Se puede encontrar más información sobre la protección del medio ambiente en la página web de Rohde & Schwarz.

# Customer Support

## Technical support – where and when you need it

For quick, expert help with any Rohde & Schwarz equipment, contact one of our Customer Support Centers. A team of highly qualified engineers provides telephone support and will work with you to find a solution to your query on any aspect of the operation, programming or applications of Rohde & Schwarz equipment.

## Up-to-date information and upgrades

To keep your instrument up-to-date and to be informed about new application notes related to your instrument, please send an e-mail to the Customer Support Center stating your instrument and your wish. We will take care that you will get the right information.

### Europe, Africa, Middle East

Phone +49 89 4129 12345  
[customersupport@rohde-schwarz.com](mailto:customersupport@rohde-schwarz.com)

### North America

Phone 1-888-TEST-RSA (1-888-837-8772)  
[customer.support@rsa.rohde-schwarz.com](mailto:customer.support@rsa.rohde-schwarz.com)

### Latin America

Phone +1-410-910-7988  
[customersupport.la@rohde-schwarz.com](mailto:customersupport.la@rohde-schwarz.com)

### Asia/Pacific

Phone +65 65 13 04 88  
[customersupport.asia@rohde-schwarz.com](mailto:customersupport.asia@rohde-schwarz.com)

### China

Phone +86-800-810-8228 /  
+86-400-650-5896  
[customersupport.china@rohde-schwarz.com](mailto:customersupport.china@rohde-schwarz.com)



# Contents

<b>1</b>	<b>User Information</b>	<b>7</b>
1.1	Foreword	7
1.2	Related Documentation	7
1.3	Purpose of the User Manual	7
1.4	Explanation of Symbols	8
<b>2</b>	<b>Safety</b>	<b>10</b>
2.1	General	10
2.2	Safety Instructions	10
<b>3</b>	<b>Description</b>	<b>12</b>
3.1	Usage	12
3.1.1	General	12
3.1.2	Explanation of Terms	12
3.1.3	System Information	13
3.2	Views	14
3.3	Construction	15
3.3.1	Case	15
3.3.2	Slot Layout	17
3.3.2.1	Plan View	17
3.3.2.2	Side View	18
3.3.3	Backplanes	18
3.3.3.1	Control Backplane	18
3.3.3.2	Analog Bus Backplane	20
3.3.3.3	Power Backplane	22
3.3.3.4	Backplane Extension R&S TS-PXB2 (Option)	22
3.3.4	Ground Concept	23
3.3.5	Geographical Addressing of the Slots with GA0 ... 2	24
3.3.6	CAN Bus	25
3.3.7	Configurations with several Frames or Option R&S TS-PXB2	26
3.3.8	Switching the PSU	27
3.3.9	Line Connection and Power Switch	27
3.3.10	Cooling	27



<b>3.4 System Module R&amp;S TS-PSYS2.....</b>	<b>28</b>
3.4.1 General.....	28
3.4.2 Characteristics.....	28
3.4.3 Circuit Diagram of the R&S TS-PSYS2.....	28
3.4.4 Structure of the R&S TS-PSYS2.....	29
3.4.5 Functional Description of the R&S TS-PSYS2.....	30
3.4.5.1 Control.....	30
3.4.5.2 System Functions.....	31
3.4.5.3 System Clock.....	32
3.4.5.4 Signal Looping.....	32
3.4.5.5 Local Signal Outputs.....	32
3.4.6 Driver Software.....	32
3.4.7 Self-Test.....	33
<b>3.5 Function Description.....</b>	<b>33</b>
<b>3.6 Permitted Module Configuration.....</b>	<b>33</b>
<b>4 Commissioning.....</b>	<b>35</b>
<b>4.1 Safety Instructions.....</b>	<b>35</b>
<b>4.2 Setting Up.....</b>	<b>35</b>
4.2.1 Requirements for Repeatable Measurements.....	35
4.2.2 Rack Mounting.....	35
4.2.3 Desktop Setup.....	36
4.2.4 Operating Position.....	36
<b>4.3 Installation.....</b>	<b>37</b>
4.3.1 Safety Instructions.....	37
4.3.2 Compatibility.....	37
4.3.3 Module Installation.....	37
4.3.4 Driver Installation.....	38
<b>4.4 Connections.....</b>	<b>38</b>
4.4.1 Line Inlet.....	38
4.4.2 Connections at the Rear.....	39
4.4.3 Connections at the Front.....	40
<b>4.5 Cabling.....</b>	<b>40</b>
4.5.1 Concept.....	40

4.5.2	Analog Bus.....	41
4.5.3	PXI Trigger Bus.....	42
4.5.4	External Cabling.....	42
4.5.5	Opening the Case.....	42
<b>5</b>	<b>Operation.....</b>	<b>44</b>
<b>5.1</b>	<b>General.....</b>	<b>44</b>
<b>5.2</b>	<b>Self-Test.....</b>	<b>44</b>
<b>5.3</b>	<b>Instrument Soft Panels.....</b>	<b>44</b>
<b>6</b>	<b>Maintenance.....</b>	<b>45</b>
<b>6.1</b>	<b>Important User Information.....</b>	<b>45</b>
<b>6.2</b>	<b>Cleaning.....</b>	<b>45</b>
<b>6.3</b>	<b>Fuse Replacement.....</b>	<b>46</b>
<b>7</b>	<b>Plug-In Modules.....</b>	<b>48</b>
<b>7.1</b>	<b>General.....</b>	<b>48</b>
<b>7.2</b>	<b>Configuration Instructions.....</b>	<b>49</b>
<b>8</b>	<b>Interface Description.....</b>	<b>50</b>
<b>8.1</b>	<b>Control Backplane.....</b>	<b>50</b>
8.1.1	Position of Interfaces.....	50
8.1.2	Connector P20 (Slots 1 ... 16).....	51
8.1.3	Connector X0 (P47).....	53
8.1.4	ATX Connectors.....	54
8.1.5	Fan Connectors X90, X91, X92, X93.....	55
8.1.6	Expansion Connector X80.....	55
8.1.7	Jumper Field.....	55
<b>8.2</b>	<b>Analog Bus Backplane.....</b>	<b>56</b>
8.2.1	Position of Interfaces.....	56
8.2.2	Analog Bus Connectors X1 ... X16.....	56
8.2.3	Analog Bus Connector X21.....	57
8.2.4	Analog Bus Connector X22.....	57
<b>8.3</b>	<b>Power Backplane (Option).....</b>	<b>58</b>
8.3.1	Position of Interfaces.....	58
8.3.2	Power Backplane Utility Connector X13.....	58

8.3.3	Power Backplane ATX Connector X12.....	59
8.3.4	Power Backplane Connector X16.....	59
8.3.5	Connector X1 (P47).....	59
<b>8.4</b>	<b>Interfaces of the R&amp;S TS-PSYS2.....</b>	<b>61</b>
8.4.1	R&S TS-PSYS2 Connector X20.....	61
8.4.2	R&S TS-PSYS2 Connector X30.....	61
8.4.3	R&S TS-PSYS2 Jumper Field X40.....	63
8.4.4	R&S TS-PSYS2 Jumper JP2.....	63
8.4.5	R&S TS-PSYS2 Jumper JP6 and JP7.....	63
8.4.6	R&S TS-PSYS2 Jumper JP8.....	63
<b>8.5</b>	<b>External Analog Interface.....</b>	<b>64</b>
8.5.1	Analog Bus Connector X2.....	64
<b>8.6</b>	<b>Backplane Extension R&amp;S TS-PXB2 (Option).....</b>	<b>65</b>
8.6.1	Jumpers.....	65
8.6.2	Rear panel slot A4 / CAN.....	65
8.6.3	Rear Panel Slot A4 / DIO of Slot A2.....	65
8.6.4	Rear Panel X1 of Slot A1.....	67
<b>9</b>	<b>Technical Data.....</b>	<b>69</b>

# 1 User Information

## 1.1 Foreword

We congratulate you on your purchase of a **ROHDE & SCHWARZ** Test System Versatile Platform R&S TS-PWA3.

We would emphasize that only attendance at one of our regular inhouse training seminars can ensure your successful operation of the Test System Versatile Platform in the long term.

Please do not hesitate to contact us should you have any queries whilst working with the Test System Versatile Platform. We look forward to working with you



**ROHDE & SCHWARZ**

GmbH & Co. KG

## 1.2 Related Documentation

Comprehensive documentation is supplied to enable you to use the Test System Versatile Platform R&S TS-PWA3 efficiently. It consists of the following documents:

- R&S TS-PWA3 User Manual
- Software User Manuals R&S GTSL, R&S EGTSL and R&S IC-Check
- User Manuals for the separate modules
- Data Sheets for the separate modules
- Service Manual



In the event of any discrepancies between data in this manual and the technical data in the data sheet, the data sheet takes precedence.

## 1.3 Purpose of the User Manual

This User Manual provides the information that is necessary for

- the commissioning and
- the proper and safe operation

of the Test System Versatile Platform R&S TS-PWA3.

This User Manual must be carefully read by the operator/engineer who is responsible for working with the R&S TS-PWA3 before it is powered up for the first time.

As well as the operating instructions and the health and safety instructions which apply at the site where the system is used, the applicable technical standards and regulations for safe and proper working must be complied with.

The operating instructions must be available at or near the R&S TS-PWA3 at all times.

The owner must supplement the operating instructions with national accident prevention and environmental protection regulations as appropriate.

## 1.4 Explanation of Symbols

The Test System Versatile Platform R&S TS-PWA3 has been manufactured in accordance with accepted engineering practice and the latest scientific and technical findings.

Nevertheless there are certain risks which cannot be designed out of equipment.

Additional safety instructions have been developed to provide adequate safety for the personnel working on the R&S TS-PWA3.

A satisfactory level of safety when using the R&S TS-PWA3 cannot be guaranteed unless these instructions are followed.

Certain sections of text are specially highlighted. These sections have the following meaning:

---

** DANGER****DANGER!**

Failure to follow instructions can result in fatal personal injury!

---

---

** DANGER****ELECTROCUTION HAZARD!**

Failure to follow instructions can result in fatal personal injury!

---

---

**NOTICE****NOTICE!**

Failure to following instructions can cause damage to the Test System Versatile Platform R&S TS-PWA3.

---

---

 **CAUTION****NOTICE!**

Failure to follow instructions can result in incorrect measurements.

---



Highlights important details to which special attention must be paid and that make work easier.

---

## 2 Safety

### 2.1 General

The Test System Versatile Platform must be operated in accordance with the safety regulations which apply in the owner's country.



Safety risks created by an application that is based on the Test System Versatile Platform must be eliminated by suitable additional arrangements (e.g. integration in the Emergency Stop circuit).



Failure to observe the safety regulations governing the operation of the Test System Versatile Platform shall void any liability or guarantee claims against ROHDE & SCHWARZ GmbH & Co. KG.

#### **WARNING**

##### **EMC Suppression**

EMC - Operating Instructions

The R&S CompactTSVP is a class-A device in keeping with CISPR 11 / EN 55011. It is suitable for use in industrial environments and areas directly connected to a low-voltage power supply that (also) supplies residential buildings.

Due to occurring grid-bound as well as radiated disturbance variables there may be problems to ensure the electromagnetic compatibility in other environments (living quarters, for example).

### 2.2 Safety Instructions

#### **DANGER**

##### **ELECTROCUTION HAZARD!**

Before opening the case, the Test System Versatile Platform must be powered off and isolated from the power supply!

The Test System Versatile Platform may only be opened by suitably trained technical personnel!

Also the rear side modules may only be exchanged by suitably trained technical personnel.

The appropriate regulations governing work carried out on electrical equipment must be complied with.



The R&S TS-PWA3 must be isolated from the electrical supply before work commences.

---

**⚠ WARNING****Shock hazard**

Before replacing a fuse, make sure that the instrument is switched off and disconnected from all power supplies.

Always use fuses supplied by Rohde & Schwarz as spare parts, or fuses of the same type and rating.

---

---

**⚠ WARNING****Shock Hazard**

The production test platforms R&S CompactTSVP and R&S PowerTSVP are designed for operating voltages up to 125 V. When working with high voltages, this voltage can apply to the analog bus connector X2. Therefore, the cable TS-PK01 must be always connected on both sides with the test systems R&S CompactTSVP and R&S PowerTSVP.

Only the cable TS-PK01 1166.4147.02 is allowed to be used with the analog bus connector X2.

To prevent injury caused by electric voltage, it is important to observe the requirements specified in EN61010-1 concerning operation with "hazardous active" voltages.

---

The electrical equipment fitted to the R&S TS-PWA3 must be checked at regular intervals. Defects such as loose connections, scorched cables etc. must be rectified immediately.

The enclosed safety sheet must be complied with.

## 3 Description

### 3.1 Usage

#### 3.1.1 General

The **Test System Versatile Platform R&S TS-PWA3** is a standardized modular platform for the program-controlled testing of modules and terminals in the factory or laboratory. With its flexible configuration and the use of worldwide standards, it can be perfectly adapted to suit the needs of the user.

The R&S TS-PWA3 is primarily intended as a flexible switching unit for measurement signals, signal sources and UUT loads. This facilitates the migration of existing and proprietary "Rack and Stack" systems to a production test platform.

R&S TS-PCA3 and R&S TS-PWA3 can be combined to create more complex ATE (**Automatic Test Equipment**) systems with a high number of test pins. The R&S TS-PWA3 is controlled either by the **system controller** of a R&S TS-PCA3 (cPCI system) or by an external PC. A serial bus system (CAN Bus) is used to trigger the modules in the R&S TS-PWA3. External cabling is used to make the connection with the measurement and trigger bus of the R&S TS-PCA3.

The R&S TS-PWA3 can be fitted with special ROHDE & SCHWARZ switching and load modules. The unit provides an analog bus that can be used to make complex connections. The modules can also be used without any modification in the R&S TS-PCA3.

The peripheral modules can be quickly and flexibly adapted to the UUTs by preceding the Test System Versatile Platform with an **adapter frame** which connects the signals securely and with a low rate of wear.

#### 3.1.2 Explanation of Terms

The following terms and standards are used in this manual:

**CompactPCI** (abbreviated to "cPCI" in this document) is an open standard of the PICMG (PCI Industrial Manufacturers Group) that adapts the PCI standard for industrial applications. It uses high-grade connection techniques and mechanical components, and applies the same electrical specifications as the PCI standard. This makes it possible to use inexpensive components and existing PCI developments even under industrial conditions. Other features include a high integration density, the option of a 19" installation and shielding for the plug-in modules. Its definition as an open standard means that a large, worldwide variety of cards is available.

This standard is used in the R&S TS-PCA3.

**PXI** (PCI eXtensions for Instrumentation) is a standard defined by National Instruments which extends cPCI. The **Test System Versatile Platform** adopts the same mechanical specifications and the interfacing with the trigger system.

**CAN** (Controller Area Network) is a serial bus system whose high system and configuration flexibility is achieved by a content-oriented addressing scheme, i.e. it defines so-called “message identifiers” and not device addresses. Systems can be added to an existing network without the need for hardware or software modifications. The CAN protocol is defined in ISO 11898.

**Rear I/O** is the name given to a design that allows input and output lines of the cPCI connectors P1 and P2 to be accessed from the rear of a backplane. Pluggable Rear I/O modules can be used for this purpose in the R&S TS-PWA3 and the R&S TS-PCA3.

### 3.1.3 System Information

The R&S TS-PWA3 has a modular structure that allows a range of system configurations tailored to the specific needs of the user.

The R&S TS-PWA3 contains 16 slots for front plug-in modules conforming to Rohde & Schwarz format. The connector P2 that is defined in the cPCI standard is referred to here as P20, because of a different assignment. Slots A3, A4 are fitted with a PSU as standard. An optional R&S TS-PCPA power pack or the optional R&S TS-PXB2 backplane extension can be plugged into slots A1 and A2. Slots 1 to 16 provide access to the PXI trigger bus, CAN bus and analog bus. If an optional R&S TS-PXB2 is used, the CAN bus is also available at slots A1 and A2. Space for Rear I/O modules is provided at the back of the R&S TS-PWA3.

The configuration of the R&S TS-PWA3 is shown in [Figure 3-1](#).

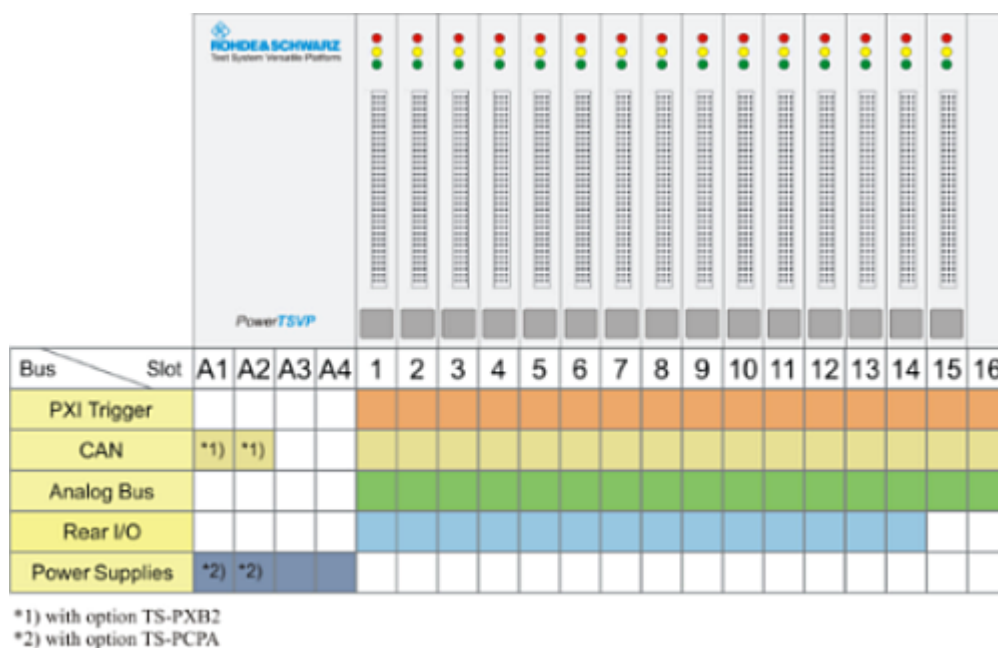

Figure 3-1: Configuration of the R&S TS-PWA3

Table 3-1 summarizes some further characteristics of the R&S TS-PWA3 that are important for a Test System Versatile Platform.

**Table 3-1: Other Characteristics R&S PowerTSVP**

Other Characteristics
Powerful cPCI PSU for 250 W (expandable to 500 W)
Controlled by CAN Bus
The internal analog bus makes it possible to distribute measurement/stimuli signals among the plug-in modules with no additional cabling work.
Optional: Front mounted adapter interface on the that uses spring contacts to facilitate rapid and high-pole contacting with the UUTs (see Figure 3-4).
System serviceability is monitored by a built-in self-test capability and system monitor (operating voltages, temperature)

## 3.2 Views

Figure 3-2 and Figure 3-3 show the R&S TS-PWA3 with slots covered

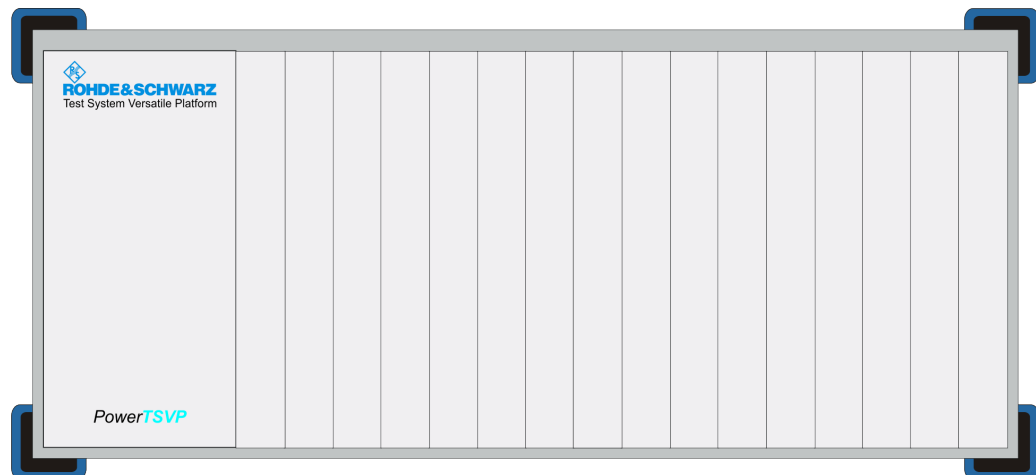

**Figure 3-2: Front View**

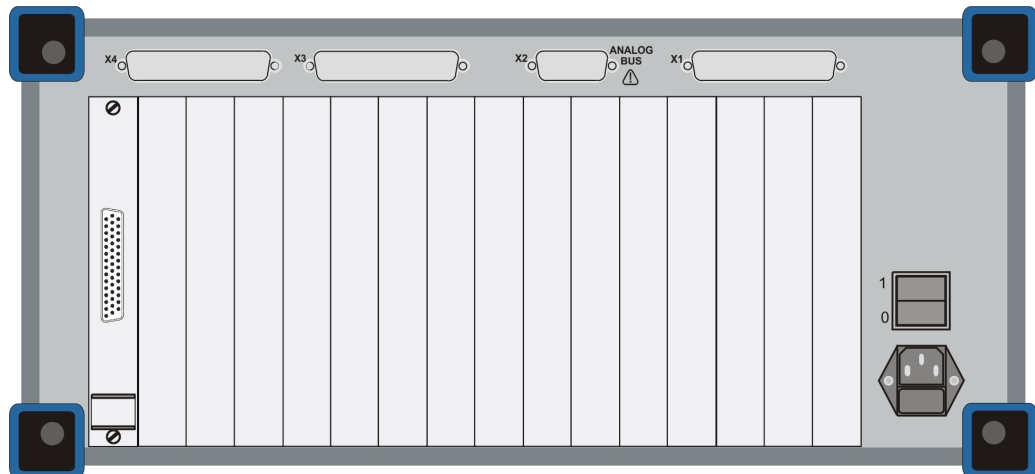

Figure 3-3: Rear View

The R&S TS-PWA3 can be operated with an adapter interface (optional) which is flange-mounted to the front panel (see [Figure 3-4](#))

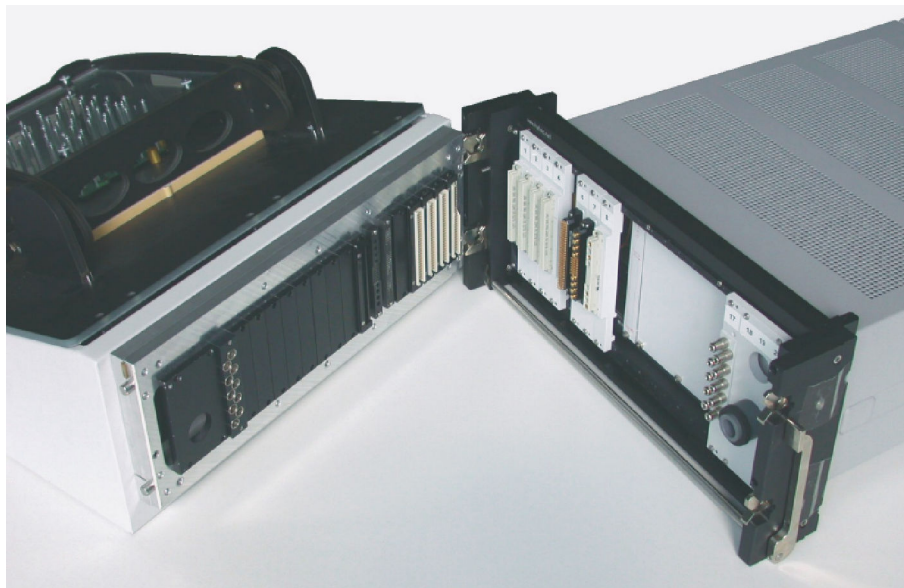

Figure 3-4: Adapter Interface

## 3.3 Construction

### 3.3.1 Case

The R&S TS-PWA3 uses the standard ROHDE & SCHWARZ case of the “Design 2000”.



**Figure 3-5: BW 2000 Case**

**Table 3-2: Features of the BW 2000 Case**

<b>HF-immune case to Rohde &amp; Schwarz “Design 2000”</b>
Dimensions: 19", height 4U, 430 mm deep
Use as desktop unit or rack-mounted case
Mounted in 19" rack using the telescopic slide set or on support rails
Side case handles that remain on the unit when mounted in the rack.
Four rugged detachable rubber feet provide rear protection.
Unused slots can be covered by front sub-panels that maintain the integrity of the HF-immunity. Contact springs are mounted between the individual front sub-panels for this purpose.
The case is suitable for 3U high plug-in boards.
The remaining space in the case can be used for adaption to the standard UUT connector or for concealed (cross) cabling.

### 3.3.2 Slot Layout

#### 3.3.2.1 Plan View

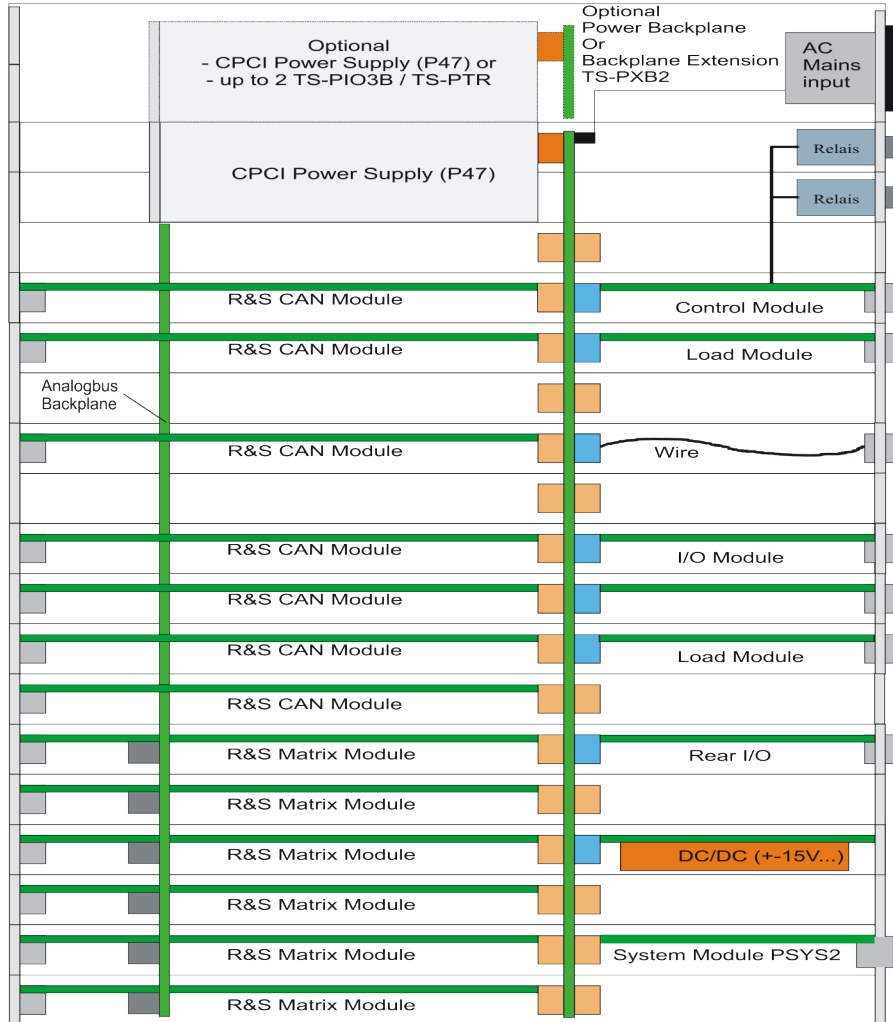

Figure 3-6: Plan View (Example)



### 3.3.2.2 Side View

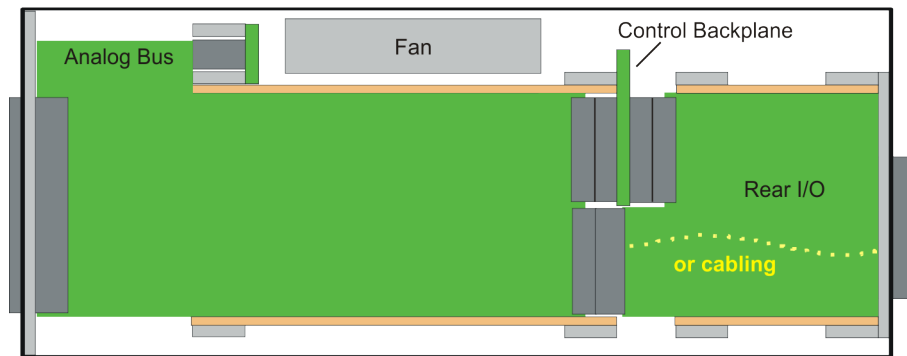

Figure 3-7: Side View

### 3.3.3 Backplanes

The R&S TS-PWA3 contains the following backplanes:

- Control backplane with PICMG Power Interface and Rear I/O support
- Analog bus backplane

Figure 3-8 shows the backplanes with the bus systems. The assignment of the connectors is detailed in Chapter 8, "Interface Description", on page 50.

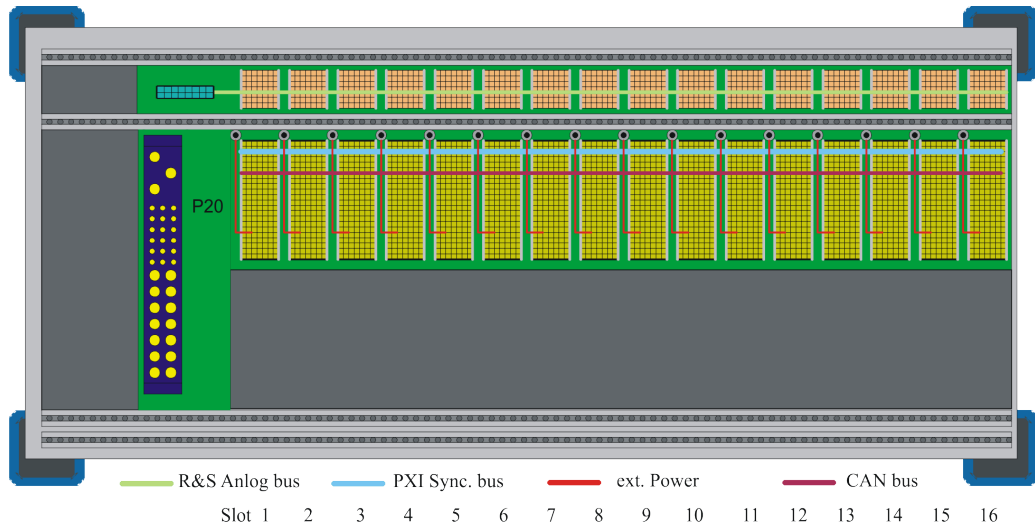

Figure 3-8: Backplanes and Bus Systems

#### 3.3.3.1 Control Backplane

The control backplane is implemented for 16 plug-in modules to R&S format with front slots. The P2 connector of the cPCI system is used for the control interface. Pin assignment is R&S-specific (designation: P20) and compatible with the R&S Com-

pactTSVP, so plug-in modules for the R&S PowerTSVP can also be operated in the R&S CompactTSVP.

Connector X0 (P47) serves as a power interface for a cPCI standard PSU. An additional PSU can be plugged onto an optional power backplane, in which case the connection with the control backplane is made with an ATX power supply cable.

Support for the Rear I/O concept according to Standard IEEE 1101.11-1998 is implemented for P20. Voltages up to 125 VDC can be routed in the Rear I/O area.

The PXI trigger bus according to PXI R2.0 is also implemented.

The **CAN bus** (according to standard CAN 2.0b (1Mbit)) is integrated as the management bus, and is available at all slots. Signals CAN\_L and CAN\_H can be terminated with jumpers and resistors ( [Figure 3-9](#)). Instead of being terminated, the bus can be extended externally using the extension connector X80.

If the optional R&S TS-PXB2 backplane extension is used, the CAN bus is also available at slots A1 and A2. The R&S TS-PXB2 is connected to the main backplane via X80. The use of the backplane extension does not change the termination principle.

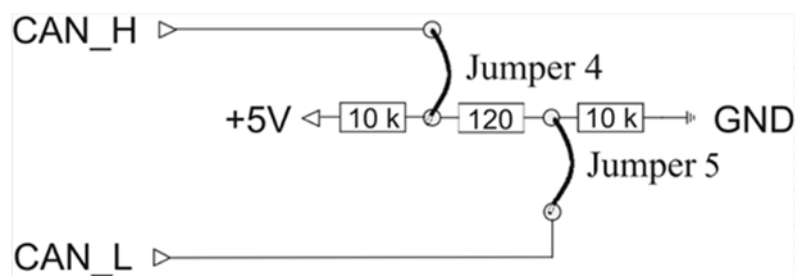

Figure 3-9: CAN Bus Termination

Table 3-3: CAN Bus

Number Lines	U max (VDC)	Pin
2	5	CAN_H: P20/C1 CAN_L: P20/D1

Two additional **external signals** (e.g. supply voltages) can be fed in via a plug-in module in P20. This input can come from an internal AC/DC module or from other external signal sources. One way in which this feature can be used is to provide a primary voltage for generating local supply voltages (DC/DC converter).

Table 3-4: External Additional Signals

Number Lines	U max (VDC)	I <sub>max</sub> /Slot(ADC)	Pin
2	60	2	input for ext. signals: P20: AUX1 B20, E19 P20: AUX2 A20, D19

Lines with +5 V and +12 V are taken from connector X0 (P47) to optional threaded studs. This makes it easy to connect AUX1 to +5 V and AUX2 to +12 V, e.g. using an optional bus bar or cable (see [Figure 3-10](#)).

Mountable Threaded Studs (option)

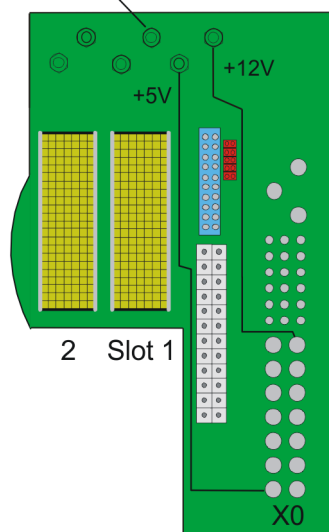

Figure 3-10: Mountable Threaded Studs on the Control Backplane

### 3.3.3.2 Analog Bus Backplane

To simplify cabling, the R&S TS-PWA3 contains an analog bus with 8 signals. The analog bus backplane is located in the front above the cPCI backplane. A special layout meets the need for high crosstalk damping and low capacitance of the signal lines to GND.

The C module (2 mm connector system) is used as the connectors (X1...X16). Plug-in modules with no analog bus connector access the analog bus via a 26-pin connector (X22) and R&S switch modules. Signals IL1\_x and IL2\_x (Instrument Line) are passed from slots 5 to 16 to connector X22.

The analog bus signals pass from connector X21 to connector X2 at the back of the R&S TS-PWA3 (see [Chapter 4.4.2, "Connections at the Rear"](#), on page 39). The electrical characteristics of the analog lines are:

- Voltage 125 VDC max.
- Current 1 A max.

### Concept of the Analog Bus

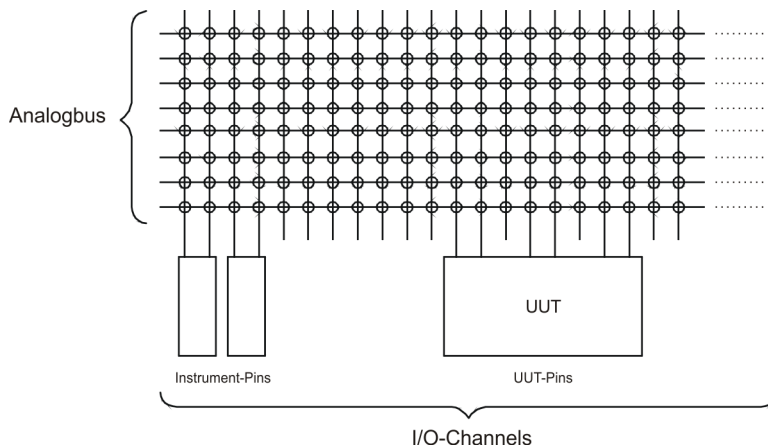

**Figure 3-11: Principle of the Analog Bus**

The analog bus in the R&S TS-PWA3 connects I/O channels of different plug-in modules to each other. These I/O channels may be connections of instruments (measuring and stimuli devices) and connections of the test device. Up to 8 signals can be connected simultaneously (see [Figure 3-11](#)).

The analog bus can be used flexibly with the ROHDE & SCHWARZ- specific plug-in modules. 8 equivalent lines are basically available (ABa1, ABa2, ABb1, ABb2, ABc1, ABc2, ABd1, ABd2). External instruments are usually connected to the R&S TS-PWA3 with a rear I/O connection. The signals for the test device are made available at the front-end connector of the various plug-in modules on the R&S TS-PWA3.

The analog bus can be used in different ways:

- as 1 bus with 8 lines
- in 2 part-buses with 4 lines each

The split of the analog bus into part-buses depends on the plug-in modules which are used and the application that is to be implemented.

The analog bus concept of the R&S TS-PWA3 fully meets the requirements that are frequently made in metrology:

- A small number of bus lines for a high number of I/O channels (e.g. In-Circuit-Test with 3 to 6 bus lines.)
- As many signals as possible simultaneously for a moderate number of I/O channels (e.g. function test with 8 lines of 50 to 100 I/O channels).
- Parallel test with split analog bus.

Line paths or higher-frequency signals are usually connected locally by special switching modules and not via the analog bus.

### Typical Use of the Analog Bus

The use of the analog bus and individual bus lines is illustrated with available R&S modules and standard modules (see [Figure 3-12](#) )

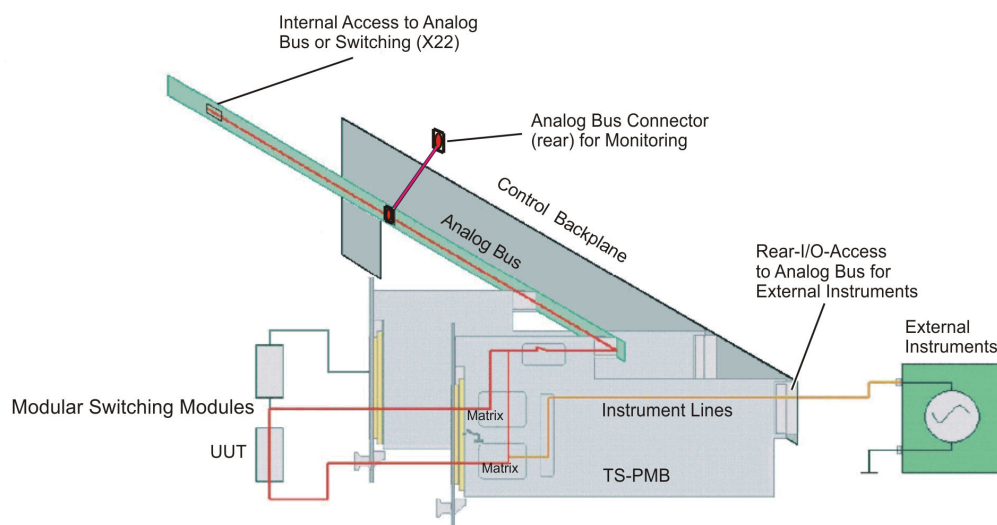

Figure 3-12: Use of the Analog Bus in the R&S TS-PWA3 (Example)

### 3.3.3.3 Power Backplane

The use of a second cPCI PSU in slots A1, A2 requires the optional Power Backplane (conforms to standard PICMG 2.0). From the Power Backplane, a cable with three connectors leads to a 24-pin ATX connector on the cPCI backplane. The three connectors are as follows (see also [Chapter 8, "Interface Description"](#), on page 50 Interface Description):

- X12, 20-pin
- X13, 10-pin
- X16, 4-pin

The second PSU can be used to boost the power of the standard PSU when connected in parallel. Alternatively it can be used to supply the device on test.

### 3.3.3.4 Backplane Extension R&S TS-PXB2 (Option)

The R&S TS-PXB2 option expands the Test System Versatile Platform R&S TS-PWA3 by 2 CAN bus slots (A1 and A2). It can be integrated ex works only.

The two slots are intended for the R&S TS-PIO3B or R&S TS-PTR options. The R&S TS-PIO3B is an 8-channel, 8-bit Open Collector Digital I/O card with additional functions.

The R&S TS-PTR is a passive feedthrough circuit board. It can be used to feed as many as 24 signals through the device.

Ports 5, 6 and 7 of the R&S TS-PIO3B in slot A1 are routed to connector X1 on the rear panel.

Ports 5, 6 and 7 of the R&S TS-PIO3B in slot A2 are available on connector DIO on the rear I/O slot A4.

In addition, the system CAN bus is available at the CAN connector on the rear I/O slot A4.

The option R&S TS-PXB2 cannot be used together with the power backplane. The jumpers and the assignment of the connectors in the rear I/O area are described in [Chapter 3.6, "Permitted Module Configuration"](#), on page 33.

### 3.3.4 Ground Concept

An electrically conductive CHA-GND (chassis GND) pad in the mounting area on the cPCI backplane provides an impedance grounding to the chassis. Screw connections and a busbar on the cPCI backplane are used to make a low-resistance connection for GND and CHA-GND, while a star connection between GND and CHA-GND using a busbar prevents unwanted ground loops.

A capacitor creates the HF connection between GND and CHA-GND at each slot. A 1 M $\Omega$  resistor discharges the capacitors and dissipates static.

A 3-pin connector provides the 230 VAC supply for the PSU on the control backplane (at X0).

The optional power backplane is supplied with AC voltage parallel to the cPCI backplane.

The PE conductor must be bonded to the case with a grounding cable.

The GND signal of the analog bus backplane is connected by a cable and screw terminal to the GND on the cPCI backplane. This prevents the large induction loops that would occur if a return via chassis were to be used.

The ground screen of the analog bus between two basic frames is connected to CHA-GND (chassis).

In the second frame, CHA-GND must not be connected to GND to prevent ground loops. The connections are indicated in [Figure 3-13](#).

GND sense of +5 V and +3.3 V (of the second PSU as well) are connected to GND at the grounding star point.

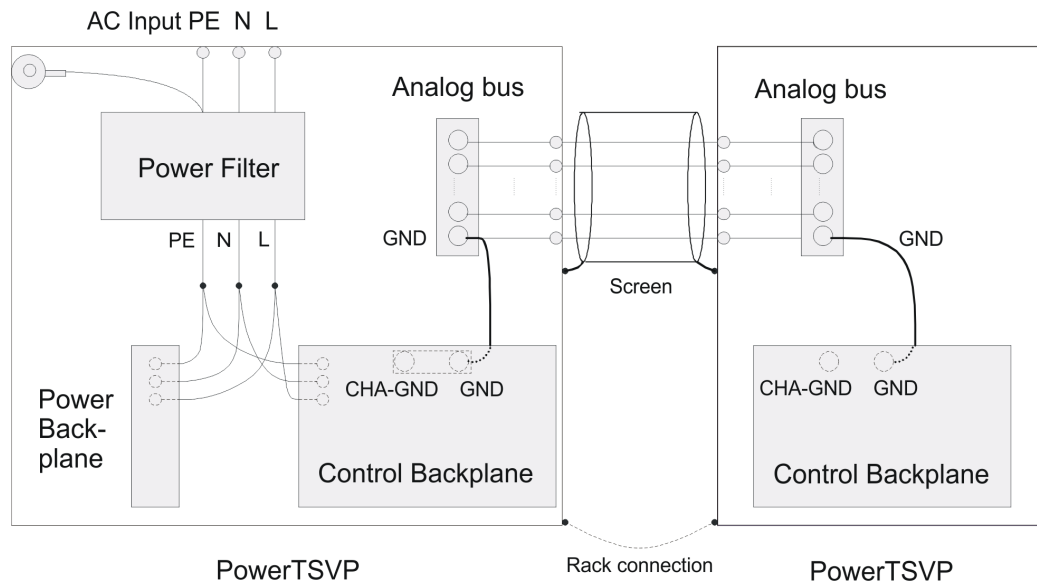

Figure 3-13: Ground Concept

### 3.3.5 Geographical Addressing of the Slots with GA0 ... 2

The physical slot addresses are coded with the signals GA0 ... GA5 (see cPCI specification). For slot 1, GA0 ... GA3 are connected to GND. In order to distinguish between slots of different connected R&S PowerTSVP basic units, GA4 and GA5 are configured with jumpers (see jumper field in [Chapter 8, "Interface Description"](#), on page 50).

The coding for slot recognition is carried out with GA0 ... GA3 as follows:

Slot	Code
1	0000
2	0001
3	0010
4	0011
5	0100
6	0101
7	0110
8	0111
9	1000
10	1001
11	1010
12	1011

Slot	Code
13	1100
14	1101
15	1110
16	1111

Note:

0: Pin connected to GND via resistor

1: Pin open

### 3.3.6 CAN Bus

For controlling of some R&S modules, the CAN bus is used in TS-PWA3. The CAN bus numbering results from the following scheme:

CANu::v::w::x

u = Board Number

v = Controller Number

w = Device Number

x = Slot Number

Board Number and Controller Number are always 0. The Device Number of the frame is determined by the settings of the jumpers on the backplane (see [Chapter 3.3.7, "Configurations with several Frames or Option R&S TS-PXB2"](#), on page 26). For Rear-I/O modules like R&S TS-PSYS1 and R&S TS-PSYS2, a 4 has to be added to the Device Number.

**Example:**

CAN0::0::5::15

Board Number: 0

Controller Number: 0

Device Number: 5 (Device 1, Rear-I/O)

Slot Number: 15

The following table shows the jumper configuration for the bus terminations CAN1 (System) und CAN2 (User).

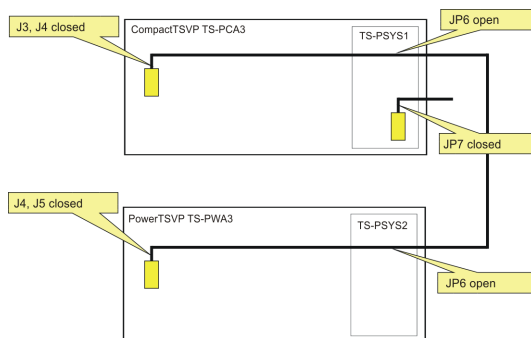

**Table 3-5: CAN Bus Termination**

Modul	CAN-Bus	open	terminated
TS-PWA3	CAN1 (System)	Jumper J3 and Jumper J4 open	Jumper J3 and Jumper J4 closed
TS-PCA3	CAN1 (System)	Jumper J4 and Jumper J5 open	Jumper J4 and Jumper J5 closed
R&S TS-PSYS1, R&S TS-PSYS2	CAN1 (System)	Jumper JP6 open	Jumper JP6 closed
R&S TS-PSYS1, R&S TS-PSYS2	CAN2 (User)	Jumper JP7 open	Jumper JP7 closed

### 3.3.7 Configurations with several Frames or Option R&S TS-PXB2

In the following figure, the terminating resistors are depicted in yellow.



**Figure 3-14: Configuration example TS-PWA3 and TS-PCA3**

CAN1 (System) is being connected between the two frames via cable R&S TS-PK02 (option). The termination is carried out on both backplanes. The jumpers on the system modules R&S TS-PSYS1 and R&S TS-PSYS2 have to be left open.

According to [Chapter 3.3.5, "Geographical Addressing of the Slots with GA0 ... 2"](#), on page 24, the jumpers for device addressing must be set as follows:

TS-PCA3: J1 set -> Device 1

TS-PWA3: J1 not set, J2 set -> Device 2

**Table 3-6: Device Addressing TS-PWA3**

J1 (GA4)	J2 (GA5)	Device
set	set	1
not set	set	2
set	not set	3
not set	not set	4

The optional R&S TS-PXB2 backplane extension also uses the CAN bus. For the modules plugged there (only R&S TS-PIO3B or R&S TS-PTR permitted), GA4 and GA5 can also be configured via jumpers. For this reason, the optional R&S TS-PXB2 backplane extension behaves like a complete device for the purpose of the CAN bus.

[Table Device Addressing for R&S TS-PXB2](#) is applicable to the optional R&S TS-PXB2 backplane extension:

**Table 3-7: Device Addressing for R&S TS-PXB2**

X11 (GA4)	X10 (GA5)	Device
set	set	1
not set	set	2
set	not set	3
not set	not set	4

If the optional R&S TS-PXB2 backplane extension is used in the R&S TS-PCA3, X10 (GA5) can remain set and X11 (GA4) can be plugged in the same way as on the main backplane. In this way, the addressing range of the CAN bus is expanded to slot codes 0000 (slot A1) and 0001 (slot A2).

If the optional R&S TS-PXB2 backplane extension is used in the R&S TS-PCA3, the R&S TS-PXB2 must be configured as a new "device" to prevent addressing collisions with slots 1 and 2.

### 3.3.8 Switching the PSU

Signal PS-ON is used to switch the PSU outputs on and off. This is done by removing Jumper 3 (see jumper field in Section 8) and replacing it by an external switch. Signal PS-ON is available at expansion connector X80.

### 3.3.9 Line Connection and Power Switch

The line inlet and power switch are at the back of the CompactTSVP (see [Figure 3-3](#)).

### 3.3.10 Cooling

The R&S TS-PWA3 features a powerful cooling concept.

The slots at the front (optional in the Rear I/O area) are cooled by a vertical flow of air. The four fans are located above the slots and are connected by inline contact connectors to the backplane. The fan speed is regulated by the internal temperature.

For the rear I/O area, fans can be retrofitted through the R&S TS-RFAN option. The supply voltage for this fan unit is tapped at the +12 V studs ([Figure 3-10](#)) and earth (sheet metal flashing).

The R&S TS-RFAN fan unit is especially required if

- for lack of space, slots cannot remain free between modules with DC/DC converter module R&S TS-PDC in the rear IO area, or
- the R&S TS-PWA3 is not operated in normal horizontal standard position.

### NOTICE

#### Heat generation

Adequate space for air inlet and outlet should be allowed when the case is rack mounted, with at least half a height unit (22 mm) being left above and below the chassis!

For desktop mounting, ensure that the case is not covered over!

## 3.4 System Module R&S TS-PSYS2

### 3.4.1 General

The R&S TS-PSYS2 is in the **Rear I/O slot 15** of the R&S TS-PWA3.

System functions such as voltage and temperature monitoring, trigger signals and optocoupler interface are used to integrate the PowerTSVP in a complete system.

### 3.4.2 Characteristics

*Table 3-8: Characteristics of the R&S TS-PSYS2*

R&S TS-PSYS2
RTM type
System functions via CAN node (microcontroller) <ul style="list-style-type: none"> <li>• Voltage monitor</li> <li>• Temperature measuring (internal)</li> <li>• Enable of the PXI trigger signals to the exterior</li> <li>• 4 optocoupler outputs</li> <li>• 4 optocoupler inputs</li> <li>• 2 switchable, short-circuit proof output voltages</li> <li>• System identification</li> </ul>
Manual selection of the local or external system clock, and its buffering with jumper

### 3.4.3 Circuit Diagram of the R&S TS-PSYS2

Figure 3-15 shows the circuit diagram of the R&S TS-PSYS2

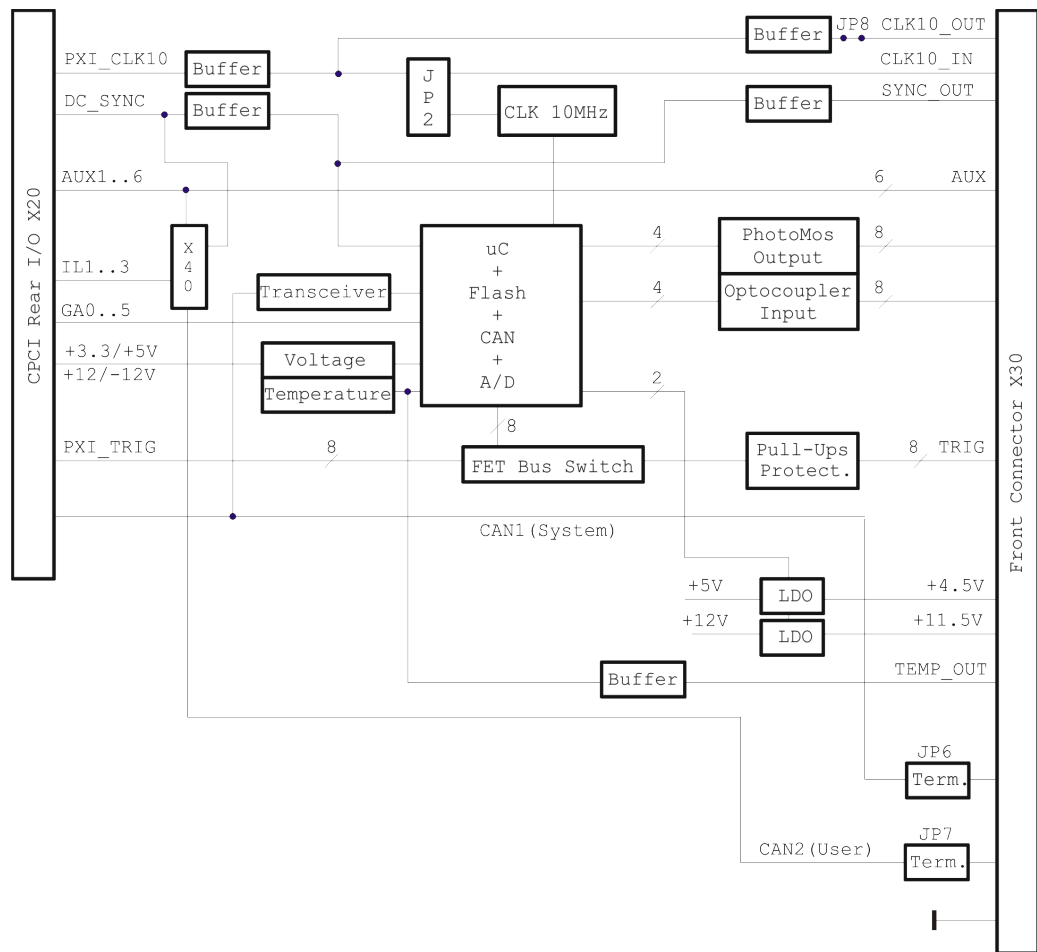

Figure 3-15: Circuit Diagram of the R&S TS-PSYS2

### 3.4.4 Structure of the R&S TS-PSYS2

The R&S TS-PSYS2 is the size of a standard cPCI-RTM (Rear Transmission Module) and is mounted in slot 15 at the rear of the TSVP chassis.

Connector X20 is used to make the connections to the Rear I/O side of the control backplane in the R&S TS-PWA3.

Jumper field X40 as well as the Jumpers JP2, JP6, JP7 and JP8 are placed on the circuit board.

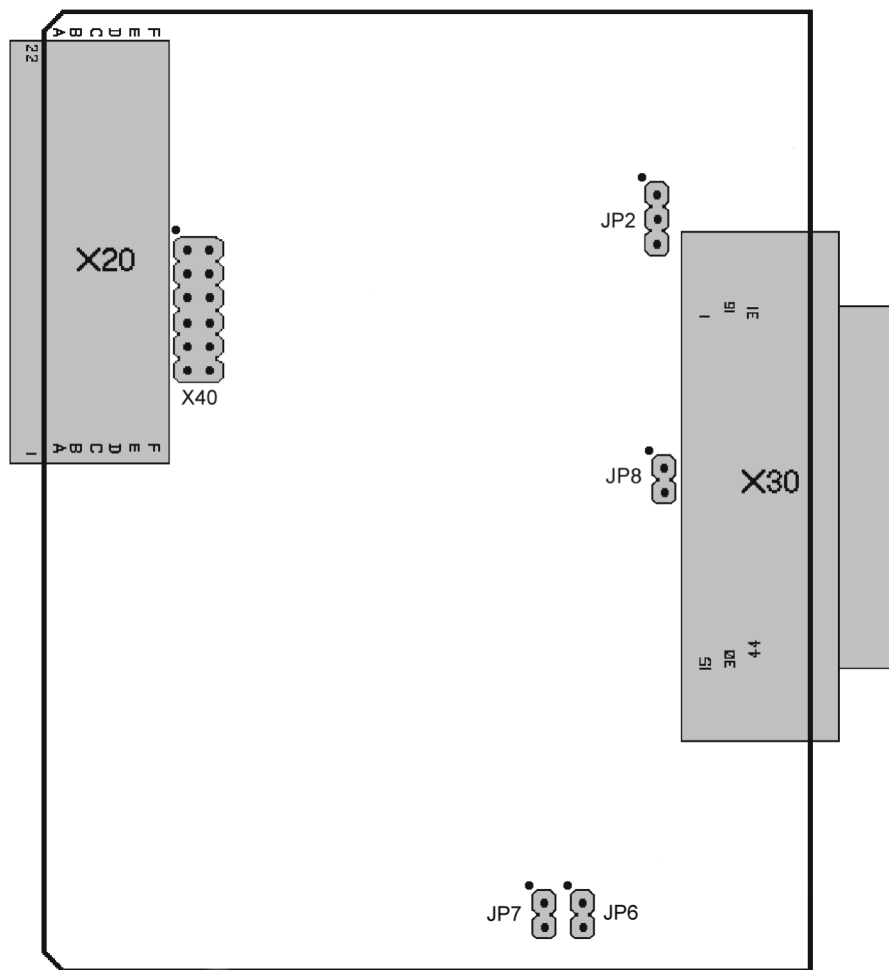

Figure 3-16: Connectors and Jumpers on the R&S TS-PSYS2

Table 3-9: Connectors on the R&S TS-PSYS2

Symbol	Use
X20	Rear I/O
X30	Front Connector
X40	Jumper field Rear I/O signals

### 3.4.5 Functional Description of the R&S TS-PSYS2

(see also [Figure 3-15](#))

#### 3.4.5.1 Control

The R&S TS-PSYS2 is controlled via CAN.

The CAN lines are terminated manually with a jumper on the R&S TS-PSYS2 (see [Chapter 8.4, "Interfaces of the R&S TS-PSYS2"](#), on page 61).

### 3.4.5.2 System Functions

The system functions are implemented by an 8 bit microcontroller which operates at a 10 MHz system speed. It communicates with the system controller in the CompactTSVP or PC across the CAN1 port. The following functions are available:

- 8 x enable of PXI trigger signals to the outside (e.g. PowerTSVP)
- 4 x optocoupler outputs (for PLC or handling systems)
- 4 x optocoupler inputs (for PLC or handling systems)
- 2 x enable for additional supply voltages (+4.5 V / +11.5 V)
- 4 x measurement of the cPCI supply voltages
- 1 x measurement of the internal temperature

#### PXI Trigger

The input/output of trigger signals (X20) is controlled separately for each signal. On the output side the signals are terminated by pullup resistors and protected by self-healing fuses and d.c. clamp diodes. The external trigger lines are available at connector X30.

#### Floating Outputs

4 PhotoMos relays (with internal current limiter) are triggered by a  $\mu$ C port. The signals are available at connector X30.

#### Floating Inputs

A  $\mu$ C port reads the status of 4 optocoupler inputs (2 x 2-pin). The current at the inputs is limited so that inputs signals can be fed in unconditioned within a wide voltage range. These inputs are available at connector X30.

#### Output Voltages

Two voltage regulators with output-enable control generate switchable, short-circuit proof voltages of +4.5 V and +11.5 V at X30. These voltages can be used to supply external components (e.g. signal lamps).

#### Measuring the cPCI Supply Voltages

The supply voltages present at connector X20 (+5 V / +12 V / -12 V) are measured with the A/D ports of the  $\mu$ C.

#### Temperature Measurement

An A/D port of the  $\mu$ C is used to measure the ambient temperature of the plug-in module. A temperature-to-voltage converter is used as the sensor. The temperature-proportional analog voltage is also output at connector X30 for monitoring purposes (TEMP\_OUT).

### Geographical Addressing

Each slot is assigned its own digital slot code (GA code). This code is used internally to directly address the  $\mu$ C.

#### 3.4.5.3 System Clock

A local quartz crystal generates the 10 MHz system clock for the system (PXI\_CLK10). Alternatively a very accurate reference clock can be fed in across X30. Jumper JP2 is used to select an internal or external clock source. The jumper functions are shown in [Chapter 8.4, "Interfaces of the R&S TS-PSYS2"](#), on page 61.

#### 3.4.5.4 Signal Looping

A number of signal lines are looped from connector X30 to connector X20. These are used to input/output Rear I/O signals (e.g. for the R&S switching modules R&S TS-PMB, R&S TS-PSAM)

Number Lines	Signal Name	Current Carrying Capacity
2	AUX1 ... 2	3 A
4	AUX3 ... 6	1.5 A

#### 3.4.5.5 Local Signal Outputs

Special signals of the R&S TS-PWA3 can be connected to connector X20 (Rear I/O) with the help of jumper field X40. The jumper functions are described in [Chapter 8.4, "Interfaces of the R&S TS-PSYS2"](#), on page 61.



Jumpers only permitted when system voltages are < 60 VDC.

Number Lines	Signal Name	Current Carrying Capacity
3	AUX4 ... 6	1.5 A
3 (6)	IL1 ... 3	1.5 A
2	CAN2	

### 3.4.6 Driver Software

The local microcontroller is triggered by the CAN1 bus and the R&S-specific protocol.

The following software modules are installed during R&S GTSL installation:

- RSCAN

- RSPSYS

### 3.4.7 Self-Test

The R&S TS-PSYS2 has no built-in self-test capability. The function of the internal CAN bus can be checked with the local CAN node.

## 3.5 Function Description

The functionality of the R&S TS-PWA3 depends essentially on the installed plug-in modules and the related software. The R&S TS-PWA3 is basically suitable for all types of production tests.

An adapter interface can be flange-mounted to the front of the R&S TS-PWA3 for the rapid and high-pole adaption of test devices (see [Figure 3-4](#))

## 3.6 Permitted Module Configuration

Because of the different properties of plug-in modules, there are restrictions on the use of plug-in slots.

Figure 3-18 shows an overview of which modules can be operated in which plug-in slots.



Permitted Module Configuration

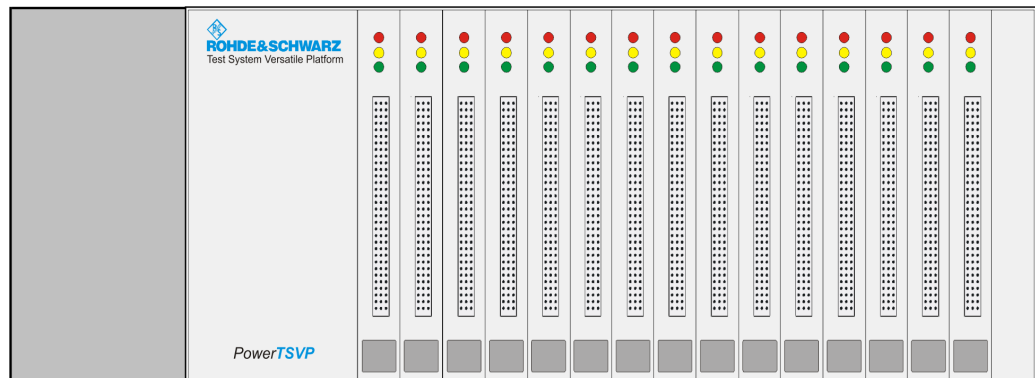

	A1	A2	A3	A4	1 *2)	2	3	4	5	6	7	8	9	10	11	12	13	14	15	16
Power-Supply																				
Power-Supply Ext. *4)																				
TS-PMB ≥ V3.0																				
TS-PMB V2.x																				
TS-PSM1																				
TS-PSM2																				
TS-PSM3																				
TS-PSM4																				
TS-PSM5																				
TS-PIO1																				
TS-PIO2																				
TS-PSU / PSU12																				
TS-PIO3B/TS-PTR *3)																				

Rear side				1	2	3	4	5	6	7	8	9	10	11	12	13	14	15	16
TS-PSYS2																			
TS-PSYS2 Option																			
TS-PDC, *1)																			
TS-PAC																			
TS-PCAL2																			
TS-PRIO																			
TS-PRIO2																			
TS-PRIO3																			
TS-PRIO4																			
TS-PRIO5																			

\*1) TS-PDC, all Versions, Frame numbering limited to 1 TS-PWA3-frame, no restriction with Version ≥ 1. , Ser ≥ 100325  
 \*2) Module solder side must be isolated against the front panel in the left neighbor slot.  
 \*3) only with optional backplane extension TS-PXB2. Cannot be combined with power backplane TS-PCPA.  
 \*4) only with optional power backplane TS-PCPA. Cannot be combined with backplane extension TS-PXB2.

Figure 3-17: Module Configuration TS-PWA3

## 4 Commissioning

### 4.1 Safety Instructions

When commissioning the Test System Versatile Platform R&S TS-PWA3 the safety instructions in [Chapter 2, "Safety"](#), on page 10 must be followed.

### 4.2 Setting Up

#### 4.2.1 Requirements for Repeatable Measurements

The ambient conditions listed below are recommended for the installation site of a Test System Versatile Platform with R&S TS-PWA3:

- Temperature variance within 24 hours not to exceed approx. 3 °C.
- Maximum temperature variance within one hour not to exceed approx. 0.5 °C.
- Extreme vibrations from mechanical or dynamic sources such as presses, power punches etc. must be avoided.
- The TSVP should be warmed up for approx. 15 minutes before measurements commence. This time will depend on the type of measuring modules and can be longer.

**Compliance with these guidelines will ensure accurate and repeatable measurements.**

#### 4.2.2 Rack Mounting

The rack mounting kit supplied by ROHDE & SCHWARZ must be used for rack mounting the TSVP.



A minimum clearance of half a height unit should be allowed above and below the R&S TS-PWA3!

This space can be used to fit filter mats.

---

The TSVP is installed in six steps:

1. Unscrew the four case feet from the base.
2. Screw the "19 inch brackets" contained in the rack mounting kit under the side handles, replacing the old screws with the longer screws.
3. Remove the four rubber tips from the unit's feet.

**Note:** Do not unscrew the rear four feet as this will loosen the body of the case!

4. Affix the self-adhesive plastic slide rails.
5. Place the unit into the rack on prepared aluminum rails.
6. Fix the R&S TS-PWA3 by screwing the "19 inch side brackets" to the rack.

**Note:** Check the position of the locknuts in the rack before sliding in the R&S TS-PWA3.

If required, insert and attach filter mats above and below the TSVP.

An optional **telescopic rail** set is also available. The telescopic rails are fitted to the side of the "BW 2000" case. The R&S TS-PWA3 can then be pushed into the prepared support in the rack.

### 4.2.3 Desktop Setup

When the R&S TS-PWA3 is set up on a desktop, the minimum gap under the unit is provided by the feet on the "BW 2000" case.

---

#### NOTICE

Do not obscure the ventilation louvers on the top of the unit! The minimum clearance of half a height unit must be ensured!

---

### 4.2.4 Operating Position

The Test System Versatile Platform R&S TS-PWA3 can be operated in the following operating positions:

- Normally, upright on the device bases on the bottom of the device
- Supported on the rear bases (on the bases holding the tube)
- Any tilt angles between the two above positions are possible.



For operating positions 2 and 3, follow the instructions according to [Chapter 3.3.10, "Cooling"](#), on page 27.

---

## 4.3 Installation

### 4.3.1 Safety Instructions

#### **NOTICE**

##### **Risk of electrostatic discharge (ESD)**

Electrostatic discharge (ESD) can cause damage to the electronic components of the instrument and the device under test (DUT). ESD is most likely to occur when you connect or disconnect a DUT or test fixture to the instrument's test ports.

To prevent ESD, use a wrist strap and cord and connect yourself to the ground, or use a conductive floor mat and heel strap combination.

### 4.3.2 Compatibility



Only the ROHDE & SCHWARZ specific modules with CAN bus triggering can be plugged into the R&S TS-PWA3.

### 4.3.3 Module Installation

To install an R&S plug-in module, proceed as follows:

- Run down and power off the R&S TS-PWA3.
- Select a suitable slot
- Remove the appropriate front panel by slackening off the screws

#### **NOTICE**

##### **Damaged backplane due to bent pins**

Bent pins may result in permanent damage to the backplane.

Check the backplane connector for bent pins!

Any pins that are bent must be straightened!

When module is connected, it must be guided with both hands and carefully pressed into the backplane connector.

- Push in the plug-in module using moderate pressure
- The top snap pin on the module must locate in the right-hand and the bottom pin in the left-hand hole on the TSVP chassis

- The module is correctly located when a distinct 'stop' can be felt
- Tighten the top and bottom screws on the front panel of the plug-in module

Please observe the following instructions for installation of a Rear I/O module:

- Rear I/O modules (for example R&S TS-PDC) must be inserted with extra caution, making certain the connector is correctly guided into the socket opening in the backplane. It must not be inserted at an angle or with incorrect alignment, etc. The short circuit board guides alone do not ensure absolutely reliable guiding.
- Multiple adjacent R&S TS-PDC modules should be inserted in order "from left to right" and removed in the opposite order. Because the spaces are so narrow, care must be taken not to damage any components on the solder side of the module.

#### 4.3.4 Driver Installation

The drivers for R&S modules will be installed together with the R&S GTSL software. The installation procedure is described in the manual *Software Description GTSL*.

For non-RS modules you have to consult the documentation supplied by the module manufacturer.

## 4.4 Connections

### 4.4.1 Line Inlet

The R&S TS-PWA3 requires a supply within the range of 110 VAC / 60 Hz or 230 VAC / 50 Hz. Fuse protection for the line inlet must not exceed a rating of 16 A.

The PSU used in the R&S TS-PWA3 has **automatic voltage selection** between 100 and 240 Volt AC (see Section 9, Technical Data).

#### 4.4.2 Connections at the Rear

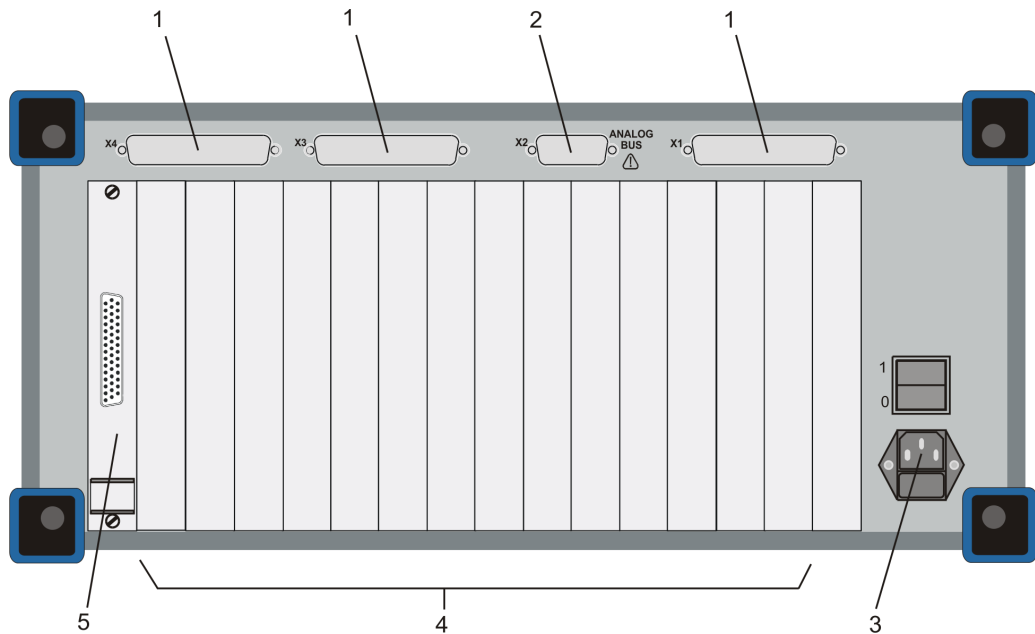

**Figure 4-1: Rear Connections without Option**

- 1 = Knockouts for system and user-specific connections
- 2 = Analog bus connections
- 3 = Power connection
- 4 = Slots for Rear I/O modules
- 5 = System module

In its basic configuration, the R&S TS-PWA3 only has the power connection (3), the analog bus connection (2) and the connector for the system module (5). All other connections are system and user-specific.

System-specific connectors (e.g. D-sub) can be installed at the back of the R&S TS-PWA3 (1). You will find more details in Section 4.5, Cabling.

### 4.4.3 Connections at the Front

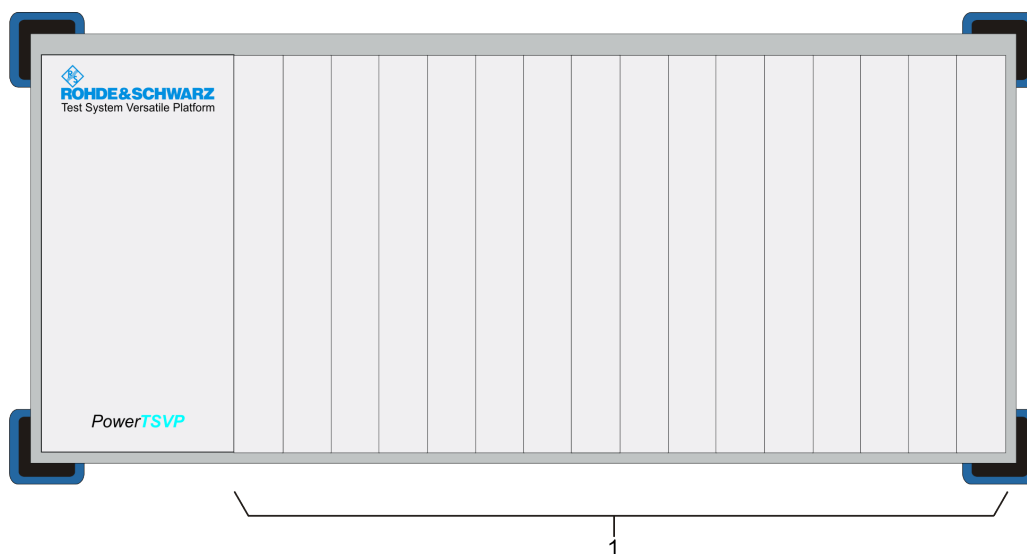

**Figure 4-2: Front Connections**

1 = Slot (16)

The Test System Versatile Platform R&S TS-PWA3 has no connections in its basic configuration. The existing slots can be fitted with system and user-specific plug-in modules and connections.

## 4.5 Cabling

### 4.5.1 Concept

The Test System Versatile Platform R&S TS-PWA3 offers comprehensive opportunities for inner, internal and external cabling:

- **Inner cabling:** Cabling by bus systems permanently installed in the R&S TS-PWA3.
  - CAN bus on the control backplane
  - PXI Trigger bus on the control backplane
  - Analog bus on separate backplane
- **Internal cabling:** Cabling inside the case of the R&S TS-PWA3. Here, plug-in modules are connected with connectors used in the R&S TS-PWA3 case:
  - Cabling of the analog bus
  - Cabling of the analog bus
  - Cabling of ROHDE & SCHWARZ modules to rear connectors or to each other
- **External cabling:** Cabling outside the case.

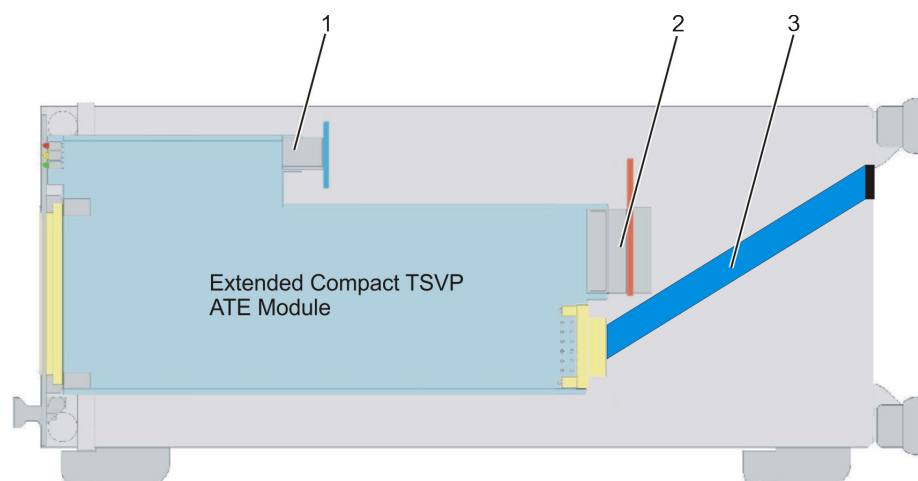

**Figure 4-3: Inner and Internal Cabling Variants**

- 1 = Analog bus
- 2 = PXI Trigger Bus
- 3 = Cabling of R&S modules to rear connectors

These various cabling options provide a number of benefits:

- Separating the adapter side (front) from the infeed of external devices (rear) creates a clear signal concept with no cross-wiring outside the case.
- Wiring is kept safe from inadvertent changes.
- The simple inner cabling concept means that modules can be quickly replaced during servicing. Bus connections are used instead of cable connections.
- System-specific connectors (e.g. D-sub) can be installed at the rear, from where signals are connected to the analog bus or the adapter interface. HF signals can also be carried in this way, for example.

## 4.5.2 Analog Bus

The analog bus is available at all slots of the R&S TS-PWA3 with its own backplane. Access for plug-in modules is implemented by connectors X1 ... X16 at the various slots and is described in [Chapter 3.3, "Construction"](#), on page 15. The following are available

- **8 bus-structured lines** for user-defined signal paths up to max. 125 VDC (1 A) between ROHDE & SCHWARZ- specific plug-in modules.



Only the Rohde & Schwarz plug-in modules use the analog bus directly. However external access to the analog bus is possible using the analog bus connector at the back of the unit.



### 4.5.3 PXI Trigger Bus

Measurement and switching modules can be synchronized with the PXI trigger bus. The external output of the signals is provided by the system module.

The following signals are available

- **Trigger bus with 8 lines** (PXI\_TRIG0 ...7)

### 4.5.4 External Cabling

External cabling is used to connect measuring and stimuli devices as well as the UUT to the R&S TS-PWA3.

Implementing the following concept should ensure the clarity of external cabling design:

- **The cabling to UUT is at the front of the R&S TS-PWA3.**  
The UUT adapter is located here; an adapter interface can also be flange mounted if required.
- **The cabling to measuring and stimuli devices is at the rear of the TSVP.**  
System and user-specific terminals and plug and socket connectors can be fitted in the back for this purpose (see [Figure 4-1](#) and [Figure 4-2](#)).

This concept ensures a high degree of clarity, rapid adaption to different test tasks and allows the simple replacement of plug-in modules.

### 4.5.5 Opening the Case

---

**⚠ DANGER****ELECTROCUTION HAZARD!**

Before opening the case, the R&S TS-PWA3 must be powered off and isolated from the power supply!

The case of the Test System Versatile Platform R&S TS-PWA3 should only be opened by qualified engineers!

The ESD (electrostatic discharge) regulations must be complied with when opening the case of the R&S TS-PWA3.

---

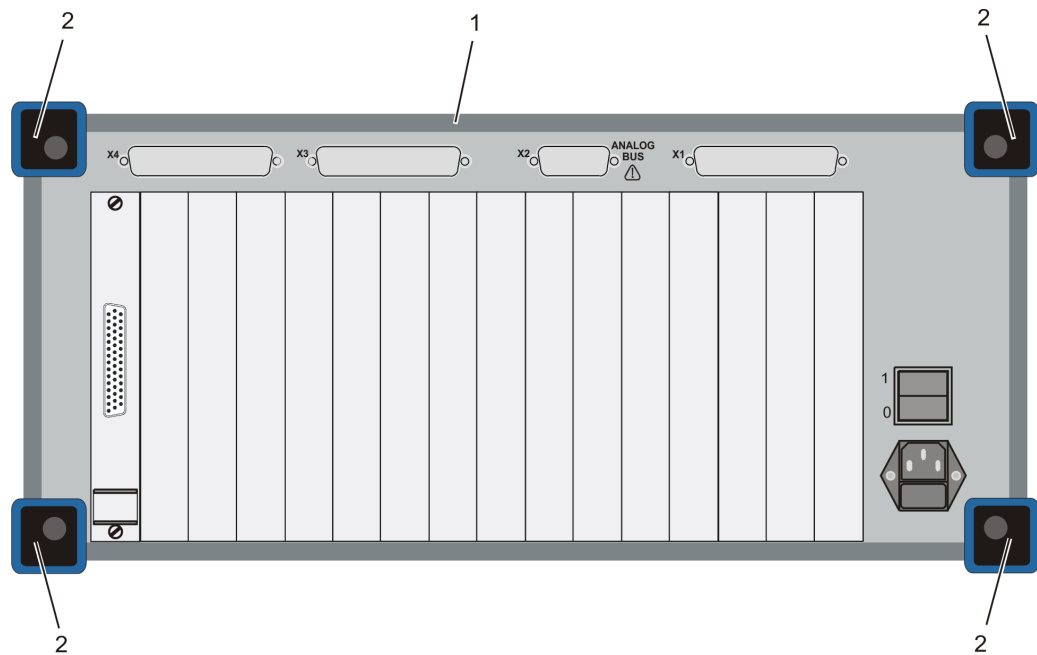

**Figure 4-4: R&S TS-PWA3 Rear View**

- 1 = Case body
- 2 = Rear case feet (4)

The case of the R&S TS-PWA3 must be opened for internal cabling purposes. To do this, proceed as follows:

1. Disconnect all connections at the front and rear of the R&S TS-PWA3.
2. Unscrew the four feet at the back of the R&S TS-PWA3.
3. Set the R&S TS-PWA3 on its front handles and carefully pull down the case body from the R&S TS-PWA3.

The R&S TS-PWA3 is now accessible from all sides. The case is closed in reverse order of opening.

## 5 Operation

### 5.1 General

The R&S TS-PWA3 does not have any controls - all operation is performed by the software.



Please refer to the appropriate documentation for details of software operation.

---

### 5.2 Self-Test

As part of the TSVP self test, an extensive test of the module is performed and an exhaustive protocol generated. This is done with the "Self-Test Support Library".

The R&S TS-PSAM module is used as a measurement unit in the TSVP self-test. The functionality of the modules in the system is ensured by measurements via the analog measurement bus.

For information on starting the self-test and the order of the work steps required as well as for a detailed description of the tested parameters and procedures, refer to the *Service Manual R&S CompactTSVP / R&S PowerTSVP*.

### 5.3 Instrument Soft Panels

The application Instrument Soft Panels permit interactive operation of all TSVP hardware modules. The Soft Panels can be used to perform all the setting, switching and measuring functions.

In addition this application offers a range of useful tools, such as "Pin Location" and "Create Physical.ini".

For details refer to manual *Software Description R&S GTSL*.

## 6 Maintenance

### 6.1 Important User Information



The Test System Versatile Platform R&S TS-PWA3 is maintenance free.

---

### 6.2 Cleaning

---

#### **⚠ DANGER**

##### **Electrocution Hazard!**

The R&S TS-PWA3 must be powered down before starting with cleaning the device.

---

The following equipment and materials are recommended for cleaning the Test System Versatile Platform R&S TS-PWA3:

- Vacuum cleaner
  - Brush
  - Soft, lint-free cloths
- 

#### **NOTICE**

##### **Damaged Test System Versatile Platform**

Never use aggressive products to clean the R&S TS-PWA3.

Electrical interfaces must not be cleaned with liquid products such as contact spray.

---

Depending on the environmental conditions, it may be necessary to remove the individual plug-in modules from the R&S TS-PWA3 and clean them with a vacuum cleaner.

**NOTICE****Risk of electrostatic discharge (ESD)**

Electrostatic discharge (ESD) can cause damage to the electronic components of the instrument and the device under test (DUT). ESD is most likely to occur when you connect or disconnect a DUT or test fixture to the instrument's test ports.

To prevent ESD, use a wrist strap and cord and connect yourself to the ground, or use a conductive floor mat and heel strap combination.

## 6.3 Fuse Replacement

The power supply to the R&S TS-PWA3 is protected by fuses. These are located in the built-in plug at the rear of the R&S TS-PWA3.

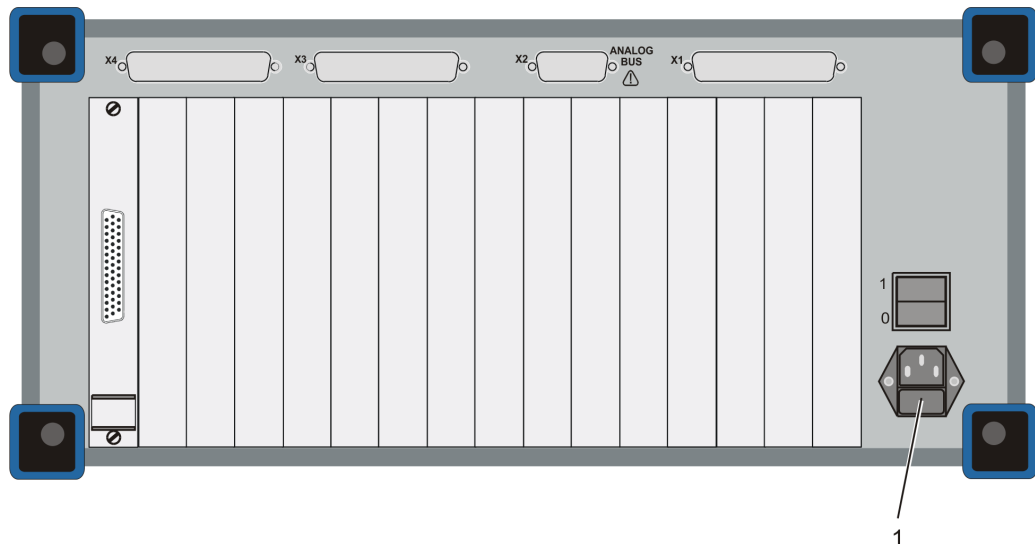

**Figure 6-1: R&S TS-PWA3 Rear View**

1 = Built-in plug with fuses (2 x IEC 127-T6.3H/250V)

A blown fuse is replaced as follows:

1. Power off the R&S TS-PWA3.
2. Isolate the R&S TS-PWA3 from the power supply (built-in plug).
3. Remove the fuseholder from the built-in plug.
4. Replace the blown fuses.



You should identify the cause of the problem and rectify it before replacing the fuse. You may be able to tell a blown fuse just by looking at it. In case of doubt, test the fuse with a multimeter.

---

**⚠ WARNING****Shock hazard**

Before replacing a fuse, make sure that the instrument is switched off and disconnected from all power supplies.

Always use fuses supplied by Rohde & Schwarz as spare parts, or fuses of the same type and rating.

---

Fuses are fitted in reverse order of removal.

## 7 Plug-In Modules

### 7.1 General

Various types of plug-in modules can be used in the R&S PowerTSVP (see [Figure 7-1](#)).

- Extended R&S PowerTSVP ATE Module (fitted depth 300 mm)
- Rear I/O modules

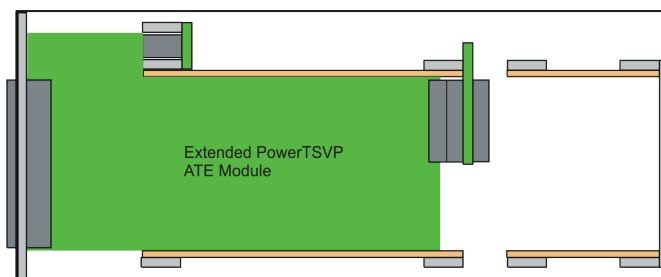
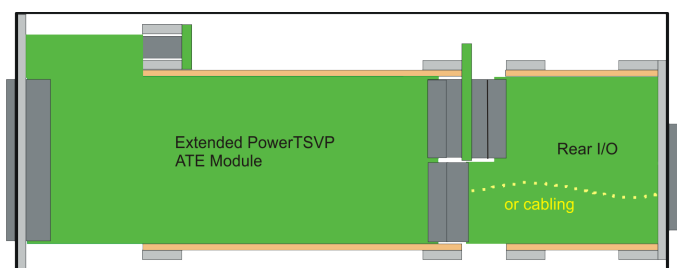

**Figure 7-1: Plug-in modules in the R&S TS-PWA3**

Connectors and connector shells to DIN 41612 suitable for the front connectors of the plug-in modules are available from a number of suppliers including

Siemens, with the following reference numbers

Case	C42334-Z61-C2
Locking lever, left	C42334-Z61-C11
Locking lever, right	C42334-Z61-C12
Round cable insert	C42334-Z61-C16
96-way connector block, type R	V42254-B1240-R960 (WireWrap pins)

Other suppliers include Harting (shells and connectors), Erni and Panduit (connectors only).



With adapters, you should remember that the count sequence on connector P20 at the back of the control backplane is the mirror image of the front.



The plug-in modules used in the R&S TS-PWA3 are described in separate documents.

## 7.2 Configuration Instructions

- Care must be taken to observe EMC regulations. Sufficient shielding can only be achieved with sectional front plates and shield springs on the inner and outer fastening level. The two levels can be connected with option R&S TS-PSK1 (HF shield wall kit). One slot is lost in this process.
- If long cards are plugged in next to short ones, care must be taken to ensure the sectional front plate of the short card cannot touch the lines of the adjacent module (risk of short circuit).
- To achieve even dissipation of heat, modules with R&S TS-PDC should not be fitted immediately next to each other if possible. This makes it easier to cool the R&S TS-PDCs, which can become quite hot. The optionally available rear I/O fan unit R&S TS-RFAN provides for enhanced cooling of the R&S TS-PDC and is required especially when the installation position is not horizontal.
- R&S TS-PSM1, R&S TS-PSM3, R&S TS-PSM4, and R&S TS-PSM5 should be connected to slot 16 so that signals from the power plug can be better directed to the back.  
For this purpose, the optional cabling kit R&S TS-PK04 (No. 1157.9104.02) can be used.  
If an additional R&S TS-PSM1 or R&S TS-PSM4 is required, it should be connected to slot 15.  
For more details, refer to the documentation of the individual modules.



# 8 Interface Description

## 8.1 Control Backplane

### 8.1.1 Position of Interfaces

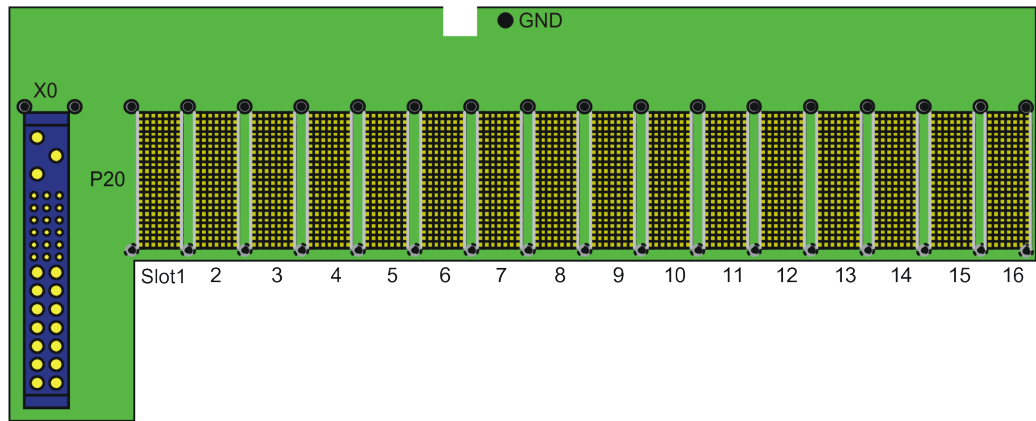

Figure 8-1: Control Backplane (Front View)

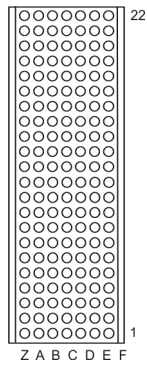

Figure 8-2: Connector P20 Rear (Mating Side)

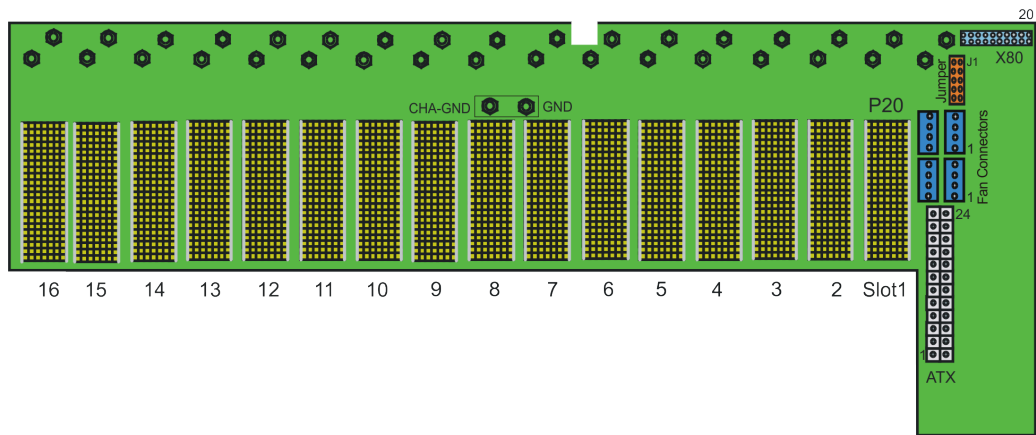

Figure 8-3: Control Backplane (Rear View)

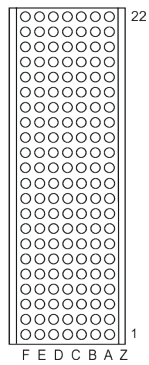

Figure 8-4: Connector P20 Rear (Mating Side)

Note: The count sequence is the mirror image of the front.

### 8.1.2 Connector P20 (Slots 1 ... 16)

NC = not connected, NP = not populated, BPIO = Backpanel I/O

Pin	Z	A	B	C	D	E	F	
22	GND	GA4	GA3	GA2	GA1	GA0	GND	P20
21	GND	PXI_LBR0	GA5	PXI_LBR1	PXI_LBR2	PXI_LBR3	GND	
20	GND	PXI_LBR4 AUX2	PXI_LBR5 AUX1	PXI_LBL0	GND	PXI_LBL1	GND	
19	GND	PXI_LBL2	GND	PXI_LBL3	PXI_LBL4 AUX2	PXI_LBL5 AUX1	GND	
18	GND	PXI_TRIG3	PXI_TRIG4	PXI_TRIG5	GND	PXI_TRIG6	GND	
17	GND	PXI_TRIG2	GND	RSV AUX3	PXI_STAR AUX4	PXI_CLK10	GND	
16	GND	PXI_TRIG1	PXI_TRIG0	RSV AUX5	GND	PXI_TRIG7	GND	
15	GND	PXI_BRSV DCSYNC	GND	RSV AUX6	PXI_LBL6 +5V	PXI_LBR6 +5V	GND	
14	NC	AD[35] BPIO	AD[34] BPIO	AD[33] BPIO	GND BPIO	AD[32] BPIO	NC	
13	NC	AD[38] BPIO	GND BPIO	V(I/O) BPIO	AD[37] BPIO	AD[36] BPIO	NC	
12	NP	AD[42] BPIO	AD[41] BPIO	AD[40] BPIO	GND BPIO	AD[39] BPIO	NP	
11	NP	AD[45] BPIO	GND BPIO	V(I/O) BPIO	AD[44] BPIO	AD[43] BPIO	NP	
10	NC	AD[49] BPIO	AD[48] BPIO	AD[47] BPIO	GND BPIO	AD[46] BPIO	NC	
9	NC	AD[52] BPIO	GND BPIO	V(I/O) BPIO	AD[51] BPIO	AD[50] BPIO	NC	
8	NC	AD[56] BPIO	AD[55] BPIO	AD[54] BPIO	GND BPIO	AD[53] BPIO	NC	
7	NC	AD[59] BPIO	GND BPIO	V(I/O) BPIO	AD[58] BPIO	AD[57] BPIO	NC	
6	NC	AD[63] BPIO	AD[62] BPIO	AD[61] BPIO	GND BPIO	AD[60] BPIO	NC	
5	NC	C/BE[5]# BPIO	GND BPIO	V(I/O) BPIO	C/BE[4]# BPIO	PAR64 BPIO	NC	
4	NC	V(I/O) BPIO	PXI_BRSV BPIO	C/BE[7]# BPIO	GND BPIO	C/BE[6]# BPIO	NC	
3	GND	PXI_LBR7 BPIO	GND	PXI_LBR8 +12V	PXI_LBR9 BPIO	PXI_LBR10 BPIO	GND	
2	GND	PXI_LBR11 BPIO	PXI_LBR12 +5V	UNC BPIO	PXI_LBL7 1-WIRE	PXI_LBL8 +12V	GND	
1	GND	PXI_LBL9 BPIO	GND	PXI_LBL10 CAN_H	PXI_LBL11 CAN_L	PXI_LBL12 +5V	GND	

Figure 8-5: Connector P20 up to Serial Number 100020 (Slots 1 ... 16)

Pin	Z	A	B	C	D	E	F	
22	GND	GA4	GA3	GA2	GA1	GA0	GND	P20
21	GND	BPIO	GA5	BPIO	BPIO	BPIO	GND	
20	GND	AUX2	AUX1	+5V	GND	+5V	GND	
19	GND	-12V	GND	+5V	AUX2	AUX1	GND	
18	GND	PXI_TRIG3	PXI_TRIG4	PXI_TRIG5	GND	PXI_TRIG6	GND	
17	GND	PXI_TRIG2	GND	AUX3	AUX4	PXI_CLK10	GND	
16	GND	PXI_TRIG1	PXI_TRIG0	AUX5	GND	PXI_TRIG7	GND	
15	GND	PXI_BRSVA15	GND	AUX6	+5V	BPIO	GND	
14	NC	BPIO	BPIO	BPIO	BPIO	BPIO	NC	
13	NC	BPIO	BPIO	BPIO	BPIO	BPIO	NC	
12	NP	BPIO	BPIO	BPIO	BPIO	BPIO	NP	
11	NP	BPIO	BPIO	BPIO	BPIO	BPIO	NP	
10	NC	BPIO	BPIO	BPIO	BPIO	BPIO	NC	
9	NC	BPIO	BPIO	BPIO	BPIO	BPIO	NC	
8	NC	BPIO	BPIO	BPIO	BPIO	BPIO	NC	
7	NC	BPIO	BPIO	BPIO	BPIO	BPIO	NC	
6	NC	BPIO	BPIO	BPIO	BPIO	BPIO	NC	
5	NC	BPIO	BPIO	BPIO	BPIO	BPIO	NC	
4	NC	BPIO	PXI_BRSVB4	BPIO	BPIO	BPIO	NC	
3	GND	RSDO	GND	BPIO	RRST#	RSA0	GND	
2	GND	RSCLK	RSA2	RSA1	RSDI	+12V	GND	
1	GND	RCS#	GND	CAN_H	CAN_L	+5V	GND	

Figure 8-6: Connector P20 as from Serial Number 100021 (Slots 1 ... 16)

### 8.1.3 Connector X0 (P47)

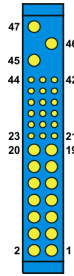

Figure 8-7: Connector X0 (P47)

Table 8-1: Assignment X0 (P47)

Pin <sup>1</sup>	<sup>2</sup>	Signal Name	Description
1-4	M	V1	V1 Output
5-12	M	RTN	V1 and V2 Return
13-18	M	V2	V2 Output
19	M	RTN	V3 Return
20	M	V3	V3 Output
21	M	V4	V4 Output
22	M	RTN	Signal Return
23	M	Reserved	Reserved
24	M	RTN	V4 Return
25	M	Reserved <sup>3</sup>	
26	M	Reserved	Reserved
27	S	EN#	Enable
28	M	Reserved <sup>3</sup>	
29	M	NC	Not connected
30	M	V1SENSE	V1 Remote Sense
31	M	Reserved <sup>3</sup>	
32	N	NC	Not connected
33	M	V2SENSE	V2 Remote Sense
34	M	S RTN	Sense Return
35	M	V1SHARE	V1 Current Share
36	M	V3SENSE	V3 Remote Sense
37	M	Reserved <sup>3</sup>	
38	M	DEG#	Degrade Signal
39	M	INH#	Inhibit

Pin <sup>1</sup>	<sup>2</sup>	Signal Name	Description
40	M	Reserved <sup>3</sup>	
41	M	V2SHARE	V2 Current Share
42	M	FAL#	Fail Signal
43	M	Reserved <sup>3</sup>	
44	M	V3SHARE	V3 Current Share
45	L	CGND	Chassis Ground
46	M	CAN	AC Input Neutral
47	M	ACL	AC Input Line

<sup>1</sup> Pin numbers illustrated are of the female backplane connector

<sup>2</sup> L=long length pins, M=medium length pins, S=short length pins

<sup>3</sup> For future options

## 8.1.4 ATX Connectors

**Table 8-2: ATX Connector Assignment**

Pin	Signal	Signal	Pin
12	V3 Current Share	V2 Current Share	24
11	5 V Sense	3.3 V Sense	23
10	+12 V	+5 V	22
9	FAL-	V1 Current Share	21
8	PW-OK	PRST-	20
7	GND Sense	GND	19
6	+5 V	GND	18
5	GND	GND	17
4	+5 V	PS-ON	16
3	GND	GND	15
2	+3.3 V	-12 V	14
1	+3.3 V	+3.3 V	13

### 8.1.5 Fan Connectors X90, X91, X92, X93

*Table 8-3: Assignment of X90 ... X93*

Pin	Signal
4	FANCTRL
3	+12 V
2	NC
1	GND

### 8.1.6 Expansion Connector X80

*Table 8-4: Assignment of X80*

Pin	Signal	Signal	Pin
1	PS-ON	GND	2
3	PW OK	GND	4
5	RESERVED	GND	6
7	CAN_H	CAN_L	8
9	IPMB_SCL(I2C)	IPMB_SDA (I2C)	10
11	+3.3 V	GND	12
13	+5V	GND	14
15	-12V	GND	16
17	+12V	GND	18
19	+12V	GND	20

### 8.1.7 Jumper Field

*Table 8-5: Jumper Field Assignment*

J1	GA4
J2	GA5
J3	PS-ON
J4	TERM_CAN_L
J5	TERM_CAN_H

## 8.2 Analog Bus Backplane

### 8.2.1 Position of Interfaces

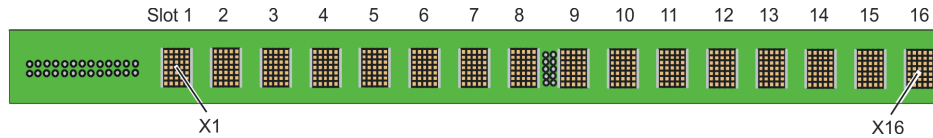

Figure 8-8: Analog Bus Backplane (Front View)

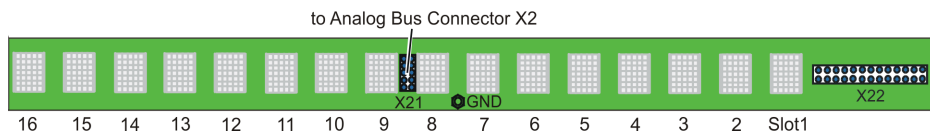

Figure 8-9: Analog Bus Backplane (Rear View)

### 8.2.2 Analog Bus Connectors X1 ... X16

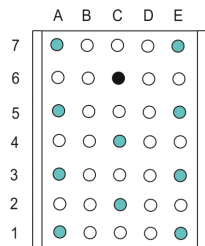

Figure 8-10: Connectors X1 ... X16 (Mating Side)

Table 8-6: Assignment of X1 ... X16

Pin	A	B	C	D	E
7	IL1_x				IL2_x
6			GND		
5	ABa1				ABc1
4			ABb1		
3	ABb2				ABc2
2			ABa2		
1	ABd1				ABd2

Note: IL1\_x = IL1 of the slot

### 8.2.3 Analog Bus Connector X21

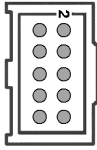

Figure 8-11: Connector X21 (Mating Side)

Table 8-7: Assignment of X21

Pin	Signal	Pin	Signal
1	GND	2	GND
3	ABc1	4	ABa1
5	ABc2	6	ABb1
7	ABa2	8	ABb2
9	ABd2	10	ABd1

### 8.2.4 Analog Bus Connector X22

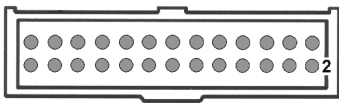

Figure 8-12: Connector X22 (Mating Side)

Table 8-8: Assignment of X22

Pin	Signal	Pin	Signal
1	IL1_5	2	IL2_5
3	IL1_6	4	IL2_6
5	IL1_7	6	IL2_7
7	IL1_8	8	IL2_8
9	IL1_9	10	IL2_9
11	IL1_10	12	IL2_10
13	IL1_11	14	IL2_11
15	IL1_12	16	IL2_12
17	IL1_13	18	IL2_13
19	IL1_14	20	IL2_14
21	IL1_15	22	IL2_15
23	IL1_16	24	IL2_16
25	GND	26	GND



Note: IL1\_5 = IL1 of slot 5

## 8.3 Power Backplane (Option)

### 8.3.1 Position of Interfaces

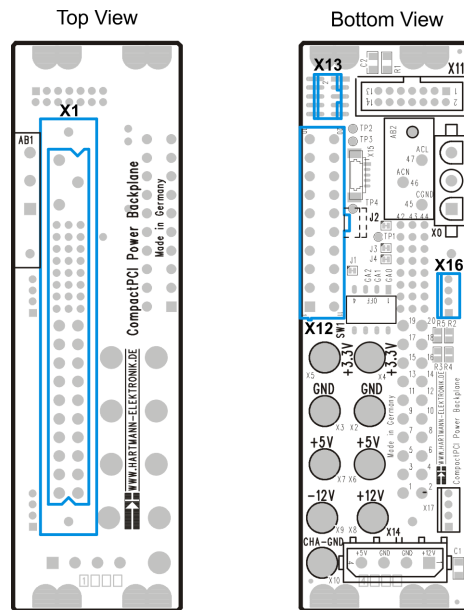

Figure 8-13: Power Backplane

### 8.3.2 Power Backplane Utility Connector X13

Table 8-9: Assignment of X13

Pin	Signal	Signal	Pin
1	PRST-	FAL-	6
2	DEG-	+3.3 V Sense	7
3	+3.3 V	GND Sense (3.3V)	8
4	+5V	+5V Sense	9
5	GND	GND Sense (5V)	10

### 8.3.3 Power Backplane ATX Connector X12

Table 8-10: Assignment of X12

Pin	Signal	Signal	Pin
10	+12 V	+5 V	20
9	NC	+5 V	19
8	PW-OK	NC	18
7	GND	GND	17
6	+5 V	GND	16
5	GND	GND	15
4	+5 V	PS-ON	14
3	GND	GND	13
2	+3.3 V	-12 V	12
1	+3.3 V	+3.3 V	11

### 8.3.4 Power Backplane Connector X16

Table 8-11: Assignment of X16

Pin	Signal
1	V1 Current Share
2	V2 Current Share
3	V3 Current Share
4	NC

### 8.3.5 Connector X1 (P47)

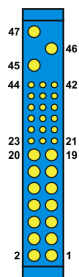

Figure 8-14: Connector X1 (P47)

Table 8-12: Assignment of X1 (P47)

Pin <sup>1</sup>	<sup>2</sup>	Signal Name	Description
1-4	M	V1	V1 Output
5-12	M	RTN	V1 and V2 Return
13-18	M	V2	V2 Output
19	M	RTN	V3 Return
20	M	V3	V3 Output
21	M	V4	V4 Output
22	M	RTN	Signal Return
23	M	Reserved	Reserved
24	M	RTN	V4 Return
25	M	Reserved <sup>3</sup>	
26	M	Reserved	Reserved
27	S	EN#	Enable
28	M	Reserved <sup>3</sup>	
29	M	NC	Not connected
30	M	V1SENSE	V1 Remote Sense
31	M	Reserved <sup>3</sup>	
32	N	NC	Not connected
33	M	V2SENSE	V2 Remote Sense
34	M	S RTN	Sense Return
35	M	V1SHARE	V1 Current Share
36	M	V3SENSE	V3 Remote Sense
37	M	Reserved <sup>3</sup>	
38	M	DEG#	Degrade Signal
39	M	INH#	Inhibit
40	M	Reserved <sup>3</sup>	
41	M	V2SHARE	V2 Current Share
42	M	FAL#	Fail Signal
43	M	Reserved <sup>3</sup>	
44	M	V3SHARE	V3 Current Share
45	L	CGND	Chassis Ground
46	M	CAN	AC Input Neutral
47	M	ACL	AC Input Line

- 1 Pin numbers illustrated are of the female backplane connector
- 2 L=long length pins, M=medium length pins, S=short length pins
- 3 For future options

## 8.4 Interfaces of the R&S TS-PSYS2

### 8.4.1 R&S TS-PSYS2 Connector X20

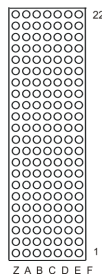

Figure 8-15: R&S TS-PSYS2 Connector X20 (Mating Side)

NC = not connected, NP = not populated

Pin	Z	A	B	C	D	E	F	
22	GND	GA4	GA3	GA2	GA1	GA0	GND	X20 C O N N E C T O R
21	GND	PXI_LBR0	GA5	PXI_LBR1	PXI_LBR2	PXI_LBR3	GND	
20	GND	AUX2	AUX1	+5 V	GND	+5 V	GND	
19	GND	-12 V	GND	+5 V	AUX2	AUX1	GND	
18	GND	PXI_TRIG3	PXI_TRIG4	PXI_TRIG5	GND	PXI_TRIG6	GND	
17	GND	PXI_TRIG2	GND	AUX3	AUX4	PXI_CLK10	GND	
16	GND	PXI_TRIG1	PXI_TRIG0	AUX5	GND	PXI_TRIG7	GND	
15	GND	DC_SYNC	GND	AUX6	+5 V		GND	
14	NC						NC	
13	NC						NC	
12	NP						NP	
11	NP			IL1			NP	
10	NC						NC	
9	NC			IL3			NC	
8	NC						NC	
7	NC			IL2			NC	
6	NC						NC	
5	NC						NC	
4	NC						NC	
3	GND		GND				GND	
2	GND					+12 V	GND	
1	GND		GND	CAN1_H	CAN1_L	+5 V	GND	

Figure 8-16: R&S TS-PSYS2 Assignment X20

### 8.4.2 R&S TS-PSYS2 Connector X30

To connect a PowerTSVP to a CompactTSVP only the cable TS-PK02 1166.4160.02 is allowed to be used for the TS-PSYS2 connector X30. The ferrite must be located toward the TS-PSYS1 module located in the CompactTSVP.

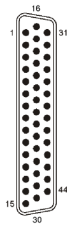

Figure 8-17: R&S TS-PSYS2 Connector X30 (Mating Side)

Table 8-13: Assignment of X30

Pin	Signal	Pin	Signal	Pin	Signal
1	AUX1	16	CLK10_IN	31	TRIG0
2	AUX2	17	CLK10_OUT	32	TRIG1
3	AUX3	18	Reserved	33	TRIG2
4	AUX4	19	GND	34	TRIG3
5	AUX5	20	+4.5 V	35	TRIG4
6	AUX6	21	+11.5 V	36	TRIG5
7	TEMP_OUT	22	GND	37	TRIG6
8	OUT1_COM	23	OUT1_NO	38	TRIG7
9	OUT2_COM	24	OUT2_NO	39	CAN2_H
10	OUT3_COM	25	OUT3_NO	40	CAN2_L
11	OUT4_COM	26	OUT4_NO	41	CAN1_H
12	IN1_H	27	IN1_L	42	CAN1_L
13	IN2_H	28	IN2_L	43	GND
14	IN3_H	29	IN3_L	44	CHA-GND
15	IN4_H	30	IN4_L		

### 8.4.3 R&S TS-PSYS2 Jumper Field X40

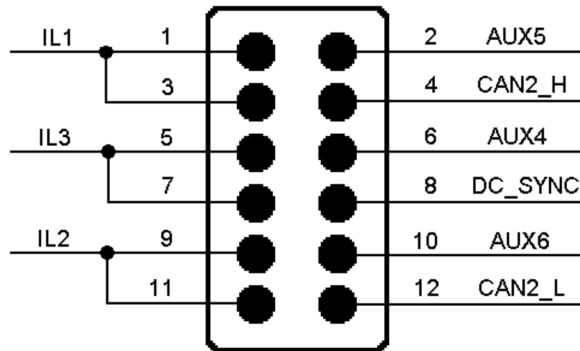

Figure 8-18: Signals at the R&S TS-PSYS2 Jumper Field X40

### 8.4.4 R&S TS-PSYS2 Jumper JP2

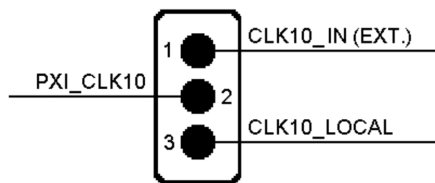

Figure 8-19: Signals at the R&S TS-PSYS2 Jumper JP2

### 8.4.5 R&S TS-PSYS2 Jumper JP6 and JP7

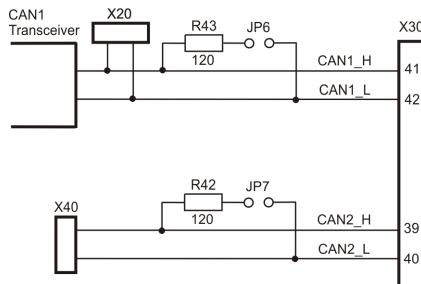

Figure 8-20: R&S TS-PSYS2 Jumper JP6 and JP7

### 8.4.6 R&S TS-PSYS2 Jumper JP8



Figure 8-21: Signal at the R&S TS-PSYS2 Jumper JP8

## 8.5 External Analog Interface

### 8.5.1 Analog Bus Connector X2

The analog bus connector X2 is located at the back of the R&S TS-PWA3 and is connected to analog bus connector X21 on the analog bus backplane.

#### **CAUTION**

Only the cable TS-PK01 1166.4147.02 is allowed to be used with the analog bus connector X2.

#### **WARNING**

##### **Shock Hazard**

The production test platforms R&S CompactTSVP and R&S PowerTSVP are designed for operating voltages up to 125 V. When working with high voltages, this voltage can apply to the analog bus connector X2. Therefore, the cable TS-PK01 must be always connected on both sides with the test systems R&S CompactTSVP and R&S PowerTSVP.

To prevent injury caused by electric voltage, it is important to observe the requirements specified in EN61010-1 concerning operation with "hazardous active" voltages.

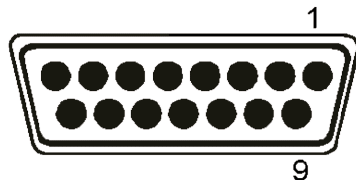

Figure 8-22: Analog Bus Connector X2 (Mating Side)

Table 8-14: Assignment of X2

Pin	Signal
1	GND
2	ABc1
3	GND
4	ABc2
5	GND
6	ABa2
7	GND

Pin	Signal
8	ABd2
9	GND
10	ABa1
11	GND
12	ABb1
13	GND
14	ABb2
15	ABd1

## 8.6 Backplane Extension R&S TS-PXB2 (Option)

### 8.6.1 Jumpers

X10 : GA5 : "0" if plugged

X11 : GA4 : "0" if plugged

X12 : +5 V available at the rear I/O slot A4 / CAN available if plugged

### 8.6.2 Rear panel slot A4 / CAN

Type: 9-pin socket.

Pin	Signal
2	CAN_L
3	GND
6	GND
7	CAN_H
9	+5V

### 8.6.3 Rear Panel Slot A4 / DIO of Slot A2

Type: 25-pin socket



Pin	Signal
1	A2_P5.IO0
2	A2_P5.IO2
3	A2_P5.IO4
4	A2_P5.IO6
5	A2_P6.IO0
6	A2_P6.IO2
7	A2_P6.IO4
8	A2_P6.IO6
9	A2_P7.IO0
10	A2_P7.IO2
11	A2_P7.IO4
12	A2_P7.IO6
13	GND
14	A2_P5.IO1
15	A2_P5.IO3
16	A2_P5.IO5
17	A2_P5.IO7
18	A2_P6.IO1
19	A2_P6.IO3
20	A2_P6.IO5
21	A2_P6.IO7
22	A2_P7.IO1
23	A2_P7.IO3
24	A2_P7.IO5
25	A2_P7.IO7

### 8.6.4 Rear Panel X1 of Slot A1

Type: 25-pin socket

Pin	Signal
1	A1_P5.IO0
2	A1_P5.IO2
3	A1_P5.IO4
4	A1_P5.IO6
5	A1_P6.IO0
6	A1_P6.IO2
7	A1_P6.IO4
8	A1_P6.IO6
9	A1_P7.IO0
10	A1_P7.IO2
11	A1_P7.IO4
12	A1_P7.IO6
13	GND
14-19	not wired
20	A1_P5.IO1
21	A1_P5.IO3
22	A1_P5.IO5
23	A1_P5.IO7
24	A1_P6.IO1
25	A1_P6.IO3
26	A1_P6.IO5
27	A1_P6.IO7
28	A1_P7.IO1
29	A1_P7.IO3

Pin	Signal
30	A1_P7.IO5
31	A1_P7.IO7
32-37	not wired

## 9 Technical Data

---



Technical data for the Test System Versatile Platform R&S TS-PWA3 is specified in the corresponding data sheets. If there are discrepancies between the information in this operating manual and the values of the data sheet, the values of the data sheet take precedence.

---